

**UNO****Boxer Series 3111 & 3211 Diaphragm Pumps***Single Pump Head, DC Power, Liquids to 1.2 LPM & Gases to 8.2 LPM***DESCRIPTION**

The DC motor driven Boxer 3000 diaphragm pumps are ideal for vacuum or pressure application where low current and reliability are prime requirements. Boxer 3000 pumps are manufactured in non-corrosive engineering materials. The wetted path is metal free. Highest quality ball bearings on cranks and motor shafts ensure the lowest current consumption with maximum operational life.

Boxer 3000 pumps are oil free. The absence of any sliding seals or components in the fluid path of the pump guarantees a contamination free transfer of media, whether liquid or gas.

The liquid version of the pump is self priming and can run dry without any adverse effects.

The exit and entry ports can be rotated and fixed in four orientations to optimise assembly in tight oem applications. No metals in flow path. Mounting bracket is included as standard.

**SPECIFICATIONS**

Max System Pressure: 2 Bar

Max Gas Flow: 8.2 l/min

Max Liquid Flow: 1.2 l/min

Liquid Suction Height: 750 mbar

Motors: 12 or 24VDC, permanent magnet, motor life approximately 6000 hours, rated for continuous duty. A 6-24 VDC low cost motor with reduced life (approximately 1200) hours, rated for intermittent duty, gas service only is also available.

Maximum Current: 390 mA

Max. Ambient Operating Temp. : 50°C

Max. Process Operating Temp. : 100°C

Materials in Flow Path: Nitrile diaphragm, silicone valves, PPS Ryton pump head. Other materials available on request.

Barb Tubing Connection: for 6.0mm diameter tubing

Weight: 377g; 233 with low cost motor

Pump Types:

Boxer 3111: Single head gas pump, 12V or 24V

Boxer 3211: Single head fluid pump, 12V or 24V

Note: Drive model 3211 at half of the rated voltage (6V for a 12V rated pump)

Accessories: Vibration mounts, dust filters with condensation traps/noise dampeners

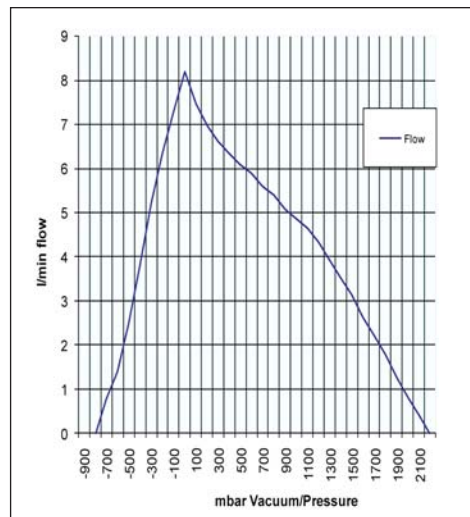
**Gas Flow Curve**

## DIMENSIONS (MM)

**Model 3111**

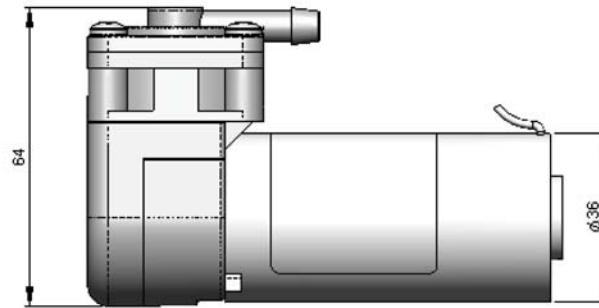
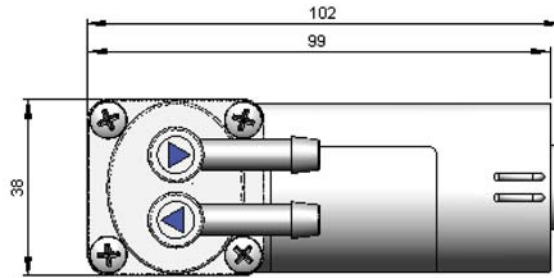
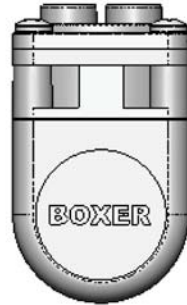

**Model 3111  
With Low Cost Motor**

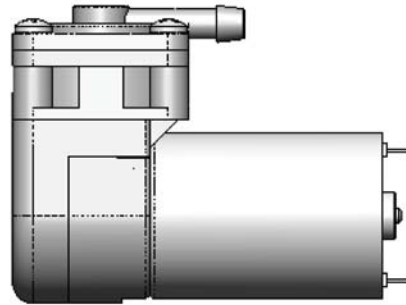
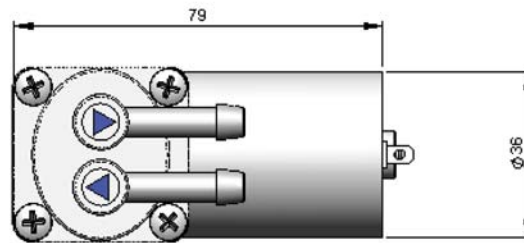
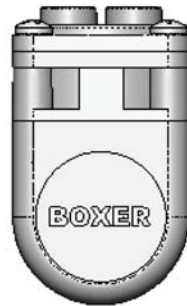

## ORDERING INFORMATION

Model	Description
3111.120	Boxer 3101, single head gas pump, 12 VDC
3111.240	Boxer 3101, single head gas pump, 24 VDC
3111.500	Boxer 3101, single head gas pump, 6-24 VDC. Low Cost
*3211.120	Boxer 3101, single head liquid pump, 12 VDC
*3211.240	Boxer 3101, single head liquid pump, 24 VDC
*Operate at half rated voltage (power 12 VDC pump with 6V)	

### Accessories & Options:

3000M- Set of 4 pump Vibration Mounts  
 AFB- Blue Dust Filters With Condensation Traps  
 AFR- Red Dust Filters With Condensation Traps