



USER MANUAL
MODEL CSLFB
ULTRASONIC FLOW TRANSMITTER



Clark Solutions
10 Brent Drive, Hudson, MA 01749
Tel. 978 / 568 3400 Fax 978 / 568 0060
www.clarksol.com

The Model CSLFB is an ultrasonic transit time flow meter designed to accurately and reliably report the flow of non-compressible fluids in pipe diameters ranging from $\frac{3}{4}$ inch to 2 inches. It is a 2-wire device reporting flow in the industry standard 4-20 mA protocol. The meter introduces no pressure drop other than the pipe section which provides the means to position the ultrasonic transducers and to connect to the user's piping system.

The small electronic board which implements all the functions to measure and report the flow is housed in the integral brass meter body and is sealed so as to protect the electronics from the environment.

THEORY OF OPERATION

Two ultrasonic transducers are positioned and angled so as to transmit and receive sound pulses that are launched at a flat reflection point located on the opposing side of the pipe. The flight time of the sound pulse from the transmitting transducer to the receiving transducer will be shortened if the pulse is launched in the direction of flow and increased if launched opposite to the direction of flow. By alternating the transmitting and receiving transducers, the difference in these transit times can be used to calculate the velocity of the flow, which when multiplied by the area of the pipe, results in a measure of volumetric flow rate which is then used to set the current in the 4-20 ma loop proportional to the full scale value of the meter.

The path of this sonic pulse traverses the pipe diameter twice and because of the generous spacing between transducers, the volume of fluid which influences the time of flight of this pulse is commensurate with the scale of the turbulence features in the flow. Turbulence by its nature has chaotic velocity components and by directing the sonic pulse through a volume comparable to the scale of this chaos, the effect on the flight time on any single measurement are much reduced, resulting in measurements that show less variation from the average. Stating it another way, a measure of the Standard Deviation of a number of measurements will be reduced, resulting in less uncertainty in the currently reported flow rate.

IMPLEMENTATION

The accuracy and precision of the determined flow rate is ultimately determined by the accuracy and precision with which one can measure the transit times.

The Model CSLFB incorporates a proprietary ASIC (Application Specific IC), which provides all the functions required to alternately transmit and receive sonic pulses and measure the transit times to picosecond accuracy. The ASIC implements the "Sing Around" method to launch and receive pulses, each received pulse initiating the next transmitted pulse. On any one measurement, a number of such cycles are used to accumulate the individual transit times which are then divided by the number of cycles to give an average of these measurements.

A microprocessor provides the following functions:

- Control and calibration of the ASIC.
- Calculations required to convert the measured times to flow rate.
- Setting of the 4-20 mA loop current to represent flow rate.
- Response to User selectable switch settings.
- Fault reporting via an optically isolated open collector output.

INSTALLATION

The Model CSLFB may be installed in any orientation, although it is recommended that in horizontal pipe runs, an orientation which positions the electrical enclosure vertically be avoided if possible. The reason for this caution is that, with any transit time meter, erratic behavior may result if bubbles are allowed to accumulate in the sound path. A mounting orientation of the electrical enclosure 90° from vertical is recommended. Install with a minimum of five pipe diameters of straight pipe, free of transitions, upstream and two pipe diameters, free of transitions, downstream of the flow transmitter.

DYNAMIC PERFORMANCE

During steady flow, the Model CSLFB updates the 4-20 Ma loop current at a rate determined by the update time as selected by SW2 (fig. 2). This update rate will either be every 10 seconds if "SLOW" response has been set or every 2 seconds if the "FAST" is set.

Air entrained in the flow, will cause erroneous measurements to be made. Algorithms have been developed that reject such measurements so that only valid measurements are retained. If a valid measurement cannot be made within 20 consecutive attempts while in the Fast mode, or within 100 consecutive attempts in the Slow mode, then a Fault condition is activated. However, any time a valid measurement can be made before the 20 or 100 second period

expires, a new 20 or 100 second period begins. This will allow the Model CSLFB to always present the last valid flow rate while a new valid measurement is being sought. Under such severe bubble conditions, the meter will still give meaningful results but with longer times between updates.

EXCEPTIONAL BEHAVIOR AND FAULT REPORTING

Three fault conditions can be detected and are reported via the Fault output provided (FIG 1).

- Failure to perform necessary internal calibrations.
- Failure to make reliable measurements.
- Flow, which exceeds 125% of the selected Full Scale option.

The electronics must, upon initialization, be able to send and receive sound pulses of a minimum strength. If it cannot, no measurements can be made. This may come about for two reasons:

- The most likely reason the electronics cannot be calibrated is because of an interrupted sound. This would be the case if the pipe was not completely filled or there is excessive air entrapped in the fluid. Of least likelihood would be a system failure. Such a failure may be a degraded transducer. Even less likely may be a failure in the control electronics.

Whenever there is a fault condition, the Opto Isolated Fault output is set to conduct and the loop current is set to 4.0 Ma. The exception is if the Fault occurs because of an over range condition. In this case the Fault output is activated but the loop current is left in excess of 20 Ma.

Watchdog Timer:

The software includes a Watchdog timer which will cause a software reset should, for whatever reason, the code is not being normally exercised for more than about 2 seconds. This reset will normally be transparent to the user. Should permanent damage to the unit have occurred, the normal fault reporting cannot be invoked and the Model CSLFB will have to be replaced.

USER SELECTABLE OPTIONS

There are three switches (FIG 3) accessible when the controller board is exposed. Their functions are as follows:

- **Reset.**

- This is a small push button switch which when activated resets the software as would occur if the unit were power cycled.

- **Full Scale**

- This is a dip switch setting that allows the User to select between two pre-programmed full scale values for the pipe diameter currently used. See the Specification section for detail.

- **Response Time**

- This switch setting allows the User to select two different update rates. In many applications, a longer update rate is desired and acceptable. With this slower update rate, the Model CSLFB will average readings over a longer time, resulting, (in the case of steady flow), a more constant reported flow rate. See the Specification section for details.

- In the case where the Model CSLFB is to be used as a feedback transducer in a control loop, a faster response time may be desirable.

Use:

If either the Full scale or Response Time switch has been changed since the last Reset or power cycle, then the Model CSLFB must be reset using the Reset switch or else power cycled.

CALIBRATION

As mentioned in the "Theory of Operation" and the "Implementation" sections, the Model CSLFB employs the Sing Around method of determining transit times. This method results in a measurement of fluid velocity which is independent of the speed of sound through the fluid and hence its dependence on temperature. This speed of sound independence removes all need for field calibration.

However, to report volumetric flow rate, this velocity must be multiplied by the cross sectional area through which the velocity was measured. This area is set by the internal pipe diameter, D. Any uncertainty in D translates directly to an uncertainty in flow rate, Q. Quantitatively,

$Q(\% \text{ error}) = 200 * d/D$, where d is the +/- tolerance of D.

As an example, a +/- .01 inch uncertainty in the nominal diameter of a 2 inch pipe would result in a +/- 1 % error in reported flow rate, Q.

At Clark Solutions each meter is calibrated against a traceable standard meter and a constant set in software, which reflects this actual diameter rather than the nominal diameter. This method of calibration removes an otherwise indeterminate error.

The error resulting from the thermal expansion of the diameter over the specified temperature range would however result in the flow rate being under reported by 0.1 %.

SPECIFICATIONS

GENERAL

Flow Range: Bi-directional, field selectable per "Standard Models" table

Accuracy: ±0.75% of full scale

Operating Temperature: -40 to 190°F (-40 to 87.8°C)

Response Time: User Selectable, 2 or 10 seconds

Viscosity Range: 0.2 to 150 cSt (0.2 to 150 mPas)

Liquid Density: 30.6 to 74.9 lb/cu.ft. (490 to 1200 kg/m³)

Max. Working Pressure: 250 PSI (17.2 bars)

Pipe Sizes: 3/4", 1", 1 1/2", 2"

Pipe Connections:

Sizes 3/4" to 2" - Female NPT, BSP

Electrical Enclosure: Integral to Body casting with gasketed cover; One 1/2" NPT conduit connection (plugged when model ordered with metric threads) and one M16 x 1.5 connection (plugged when model ordered with NPT threads)

Electrical Connections: Screw terminal connections on PC board

Enclosure Rating: NEMA 4 (IP 65)

Power Supply: 18 to 36 VDC

WETTED MATERIALS

Ultrasonic Transducers: ULTEM® Encapsulated

Seals: EPDM, Buna-N, Neoprene™, FKM, or other

Body Material: Brass (UNS C83600)

OUTPUT

Analog: 2-wire, 4-20 mA output; Output is 4 mA from zero to min. flow (see Standard Model table)

Load Resistance: See FIG. 4

Error Detection: An optically isolated sink output is activated under certain detectable fault conditions, such as transducer failure or overly noisy output due to flow stream anomalies, as might be seen due to excessive bubble entrainment. The optional Fault output is an optically isolated NPN transistor capable of sinking up to 25 mA from a voltage source of no more than 48 VDC.

Caution: There is no current limiting on this output so care must be exercised to limit the sink current to less than 25 ma and insure that proper polarity, as shown in Fig.1, is observed else permanent damage may result.

Direction of Flow: Optional output to indicate direction of flow is available. Activation or deactivation of an optically isolated 25 mA (max. 48V no load voltage) sink output indicates flow direction. Error detection is not available when this option is ordered.

WIRING

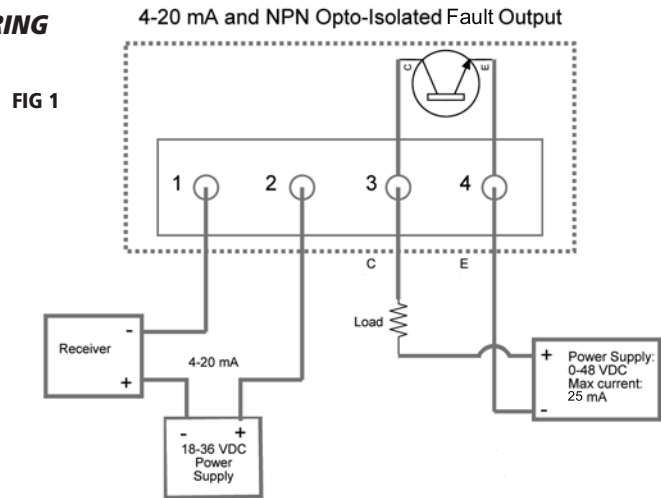
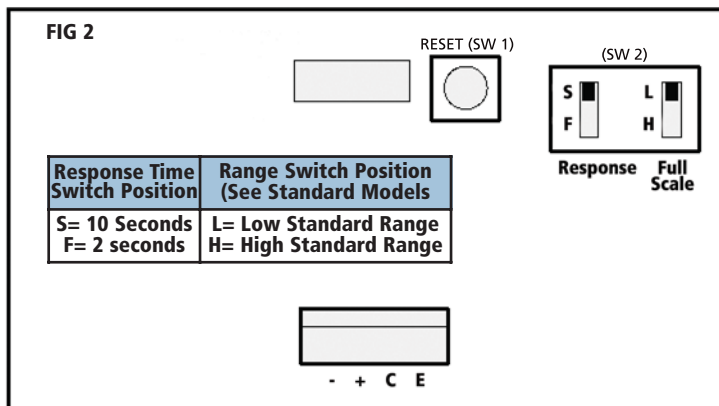

FIG 2



BOARD LOCATIONS OF REFERENCED USER FUNCTIONS

OPTIONAL CONNECTORS

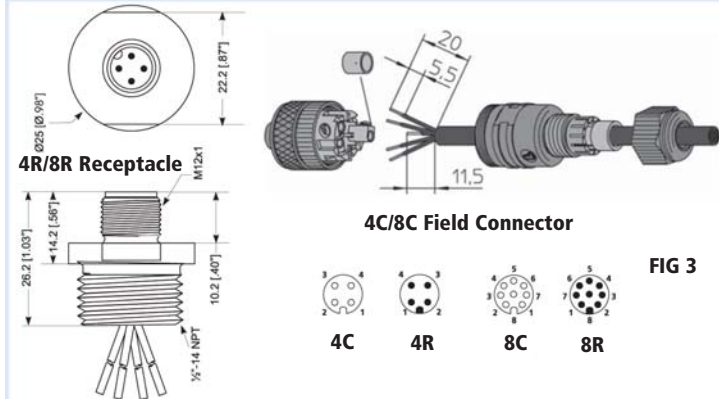
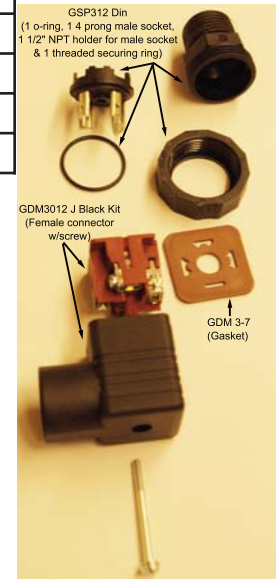

FIG 3

Transmitter Connection Terminal	8-Pin (8C) Connector	8-pin Connector Cable	4-Pin (4C) Connector	4-pin Connector Cable
+	1	Brown	1	Red
-	2	White/Brown	2	Black
C (Collector)	3	Green	3	White
E (Emmitter)	4	White/Green	4	Green
RTD Red	5	Orange		
RTD Red	6	White/Blue		
RTD White	7	Blue		

4H Hirshmann Connector

- 1) GSP312 assembly is factory installed on to the flow transmitter.
- 2) Insert wire cable through female connector shell of GDM3012J and fasten wire conductors to terminals per below table.
- 3) Install GDM 3-7 gasket on to the 4-prong connector of GSP312 assembly.
- 4) Plug the connector to the GSP312 assembly and snap on shell in the desired orientation.
- 5) Secure assembly with the supplied mounting screw.



Terminal	4-20 mA and NPN Alarm Output	4-20 mA and 100 Ohm RTD
—	(-) V_{in} Return, 4-20 mA	(-) V_{in} Return, 4-20 mA
1	(+) V_{in} Supply, 18-36 VDC, 4-20 mA	(+) V_{in} Supply, 18-36 VDC, 4-20 mA
2	C Alarm (Collector)	RTD
3	E Alarm (Emmitter)	RTD

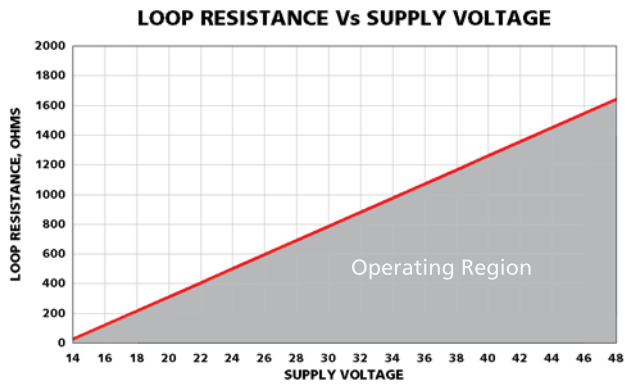

FIG 4

STANDARD MODELS

Model	Pipe Size/Thread Size	*Field Selectable Full Scale Ranges (GPM)		*Field Selectable Full Scale Ranges (LPM)		
		Min.	Max.	Min.	Max.	
CSLFB34	3/4" NPT or BSP	L	0.23	15	0.90	60
		H	0.38	25	1.50	100
CSLFB10	1.0" NPT or BSP	L	0.45	30	1.70	115
		H	0.75	50	3.00	200
CSLFB15	1.50" NPT or BSP	L	0.60	40	2.30	150
		H	1.20	80	4.50	300
CSLFB20	2.0" NPT or BSP	L	0.90	60	3.40	225
		H	1.80	120	6.80	455

*Other F.S. ranges can be specified

DIMENSIONS

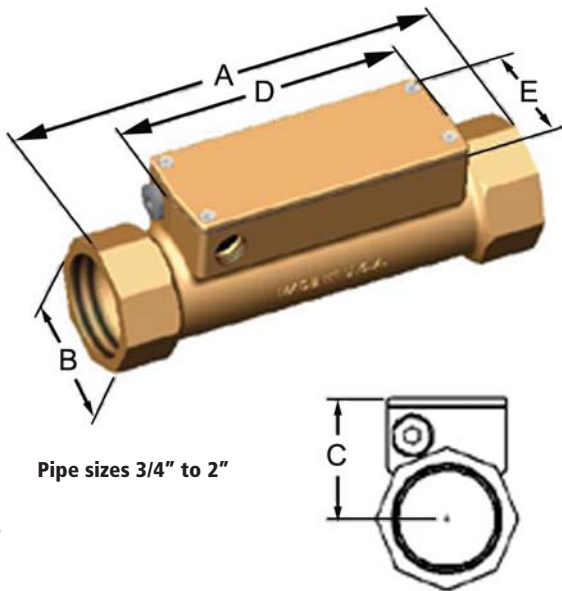

FIG 5

Size/Connection	A		B		C		D		E	
	Inches	mm	Inches	mm	Inches	mm	Inches	mm	Inches	mm
3/4" & 1"	9.20	234	1.62	41.10	2.06	52.30	6.40	163	2.40	61.00
1-1/2" & 2"	9.88	251	2.75	69.90	2.51	63.80	6.40	163	2.40	61.00

CAUTION

Model CSLFB is for measurement of liquid flows only
Use only with liquids compatible with the materials of construction
Maximum Pressure: 250 PSIG
Maximum Temperature: 190°F