



Liquid Ultrasonic Flow Transmitters

Loop Powered 4-20 mA Output, Flows to 120 GPM, 3/4" to 2" Pipe, Brass

DESCRIPTION

Clark Sonic® ultrasonic flow transmitters are ideal for measurement of flow rates of acoustically conductive liquids including most clean liquids and many liquids with entrained solids.

Main advantages include excellent long term stability, no pressure drop, broad fluid compatibility, high accuracy and low cost. Also, there are no moving parts.

At the heart of the transmitter is a proprietary mixed signal ASIC which allows sophisticated timing, control and transducer drive circuitry to be combined on a single integrated circuit. The ASIC uses a special algorithm that is an improvement upon the standard single-path measurement technique. Using the "sing around" method, the ultrasonic transducer alternates between transmitting and receiving to measure differences in flight time between upstream and downstream transmissions. A sound pulse is transmitted from an upstream transducer towards a downstream transducer like a traditional time-of-flight measurement. However, the received sound pulse then triggers a second downstream transmission, that then triggers a third and so on for a specific number of cycles. This process is repeated in the upstream direction.

Because it takes an average flight time over multiple cycles to compute the difference in flight times, the approach yields a significant improvement in timing accuracy when compared with the time-of-flight difference of a single sound pulse in each direction. This algorithm, combined with the pico-second timing resolution of the ASIC, provides the precise time measurement capability necessary for compact, small diameter ultrasonic meters.

The output of the transmitter is unaffected by changes in fluid temperature, density and viscosity as the flow calculation is independent of the speed of sound.

Wetted materials include ULTEM® encapsulated ultrasonic transducers with a choice of elastomer seals and Brass body material.



SPECIFICATIONS

GENERAL

Flow Range: Bi-directional, field selectable per "Standard Models" table

Accuracy: ±0.75% of full scale

Operating Temperature: -40 to 190°F (-40 to 87.8°C)

Response Time: User Selectable, 2 or 10 seconds

Viscosity Range: 0.2 to 150 cSt (0.2 to 150 mPas)

Liquid Density: 30.6 to 74.9 lb/cu.ft. (490 to 1200 kg/m³)

Max. Working Pressure:

3/4" to 2": 250 PSI (17.2 bars)

Pipe Sizes: 3/4", 1", 1 1/2", 2"

Pipe Connections:

Sizes 3/4" to 2" - Female NPT, BSP

Electrical Enclosure: Integral to Body casting with gasketed cover; One 1/2" NPT conduit connection (plugged when model ordered with metric threads) and one M16 x 1.5 connection (plugged when model ordered with NPT threads)

Electrical Connections: Screw terminal connections on PC board

Enclosure Rating: NEMA 4 (IP 65)

Power Supply: 18 to 36 VDC

WETTED MATERIALS

Ultrasonic Transducers: ULTEM® Encapsulated

Seals: EPDM, Buna-N, Neoprene™, FKM, or other

Body Material: Brass (UNS C83600)

OUTPUT

Analog: 2-wire, 4-20 mA output; Output is 4 mA from zero to min. flow (see Standard Model table)

Error Detection: An optically isolated sink output is activated under certain detectable fault conditions, such as transducer failure or overly noisy output due to flow stream anomalies, as might be seen due to excessive bubble entrainment. The optional Fault output is an optically isolated NPN transistor capable of sinking up to 25 mA from a voltage source of no more than 48 VDC.

Direction of Flow: Optional output to indicate direction of flow is available. Activation or deactivation of an optically isolated 25 mA sink output indicates flow direction. Error detection is not available when this option is ordered.

Optional Temperature Sensor: 3 wire RTD, 100 Ohm, Platinum, Class A, IEC60751, built in to transducer shell for monitoring process temperature; optional 4 or 8 pin electrical connector recommended with this option

Optional NEMA 4 four or eight-pin receptacles installed in transmitter conduit connection and factory wired along with mating simplify field installation

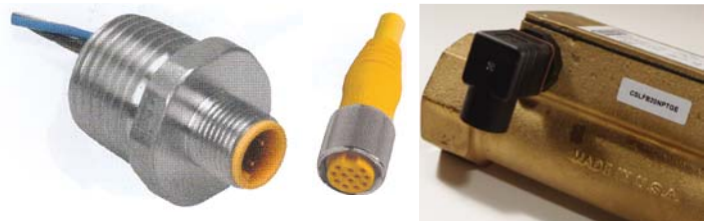

4R/C & 8R/C circular

4H-Hirschmann Connector

DIMENSIONS

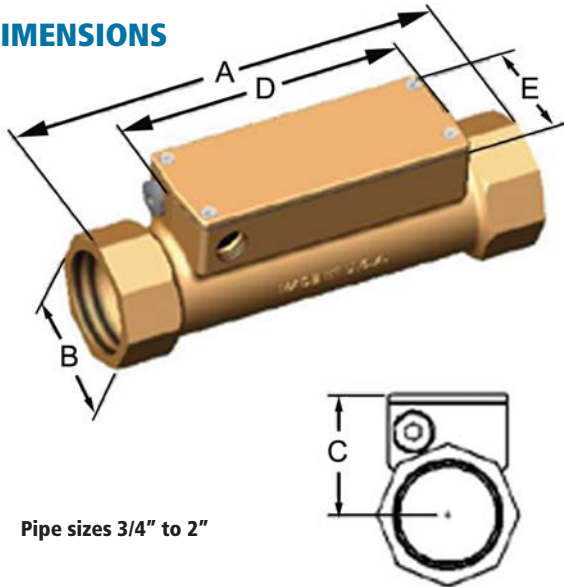

Pipe sizes 3/4" to 2"

LOOP RESISTANCE Vs SUPPLY VOLTAGE

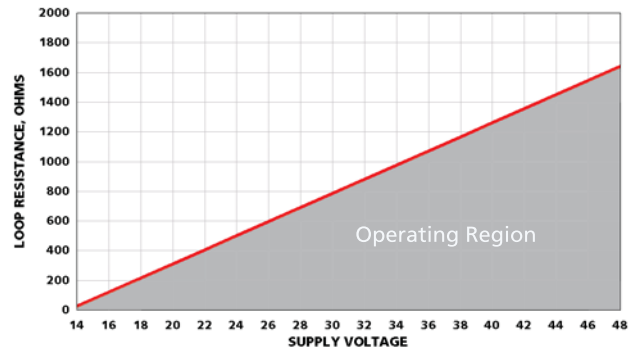

| Size/Connection | A | | B | | C | | D | | E | |
|-----------------|--------|-----|--------|-------|--------|-------|--------|-----|--------|-------|
| | Inches | mm | Inches | mm | Inches | mm | Inches | mm | Inches | mm |
| 3/4" & 1" | 9.20 | 234 | 1.62 | 41.10 | 2.06 | 52.30 | 6.40 | 163 | 2.40 | 61.00 |
| 1-1/2" & 2" | 9.88 | 251 | 2.75 | 69.90 | 2.51 | 63.80 | 6.40 | 163 | 2.40 | 61.00 |

STANDARD MODELS

| Model | Pipe Size/Thread Size | *Field Selectable Full Scale Ranges (GPM) | | *Field Selectable Full Scale Ranges (LPM) | | |
|---------|-----------------------|---|------|---|------|-----|
| | | Min. | Max. | Min. | Max. | |
| CSLFB34 | 3/4" NPT or BSP | L | 0.23 | 15 | 0.90 | 60 |
| | | H | 0.38 | 25 | 1.50 | 100 |
| CSLFB10 | 1.0" NPT or BSP | L | 0.45 | 30 | 1.70 | 115 |
| | | H | 0.75 | 50 | 3.00 | 200 |
| CSLFB15 | 1.50" NPT or BSP | L | 0.60 | 40 | 2.30 | 150 |
| | | H | 1.20 | 80 | 4.50 | 300 |
| CSLFB20 | 2.0" NPT or BSP | L | 0.90 | 60 | 3.40 | 225 |
| | | H | 1.80 | 120 | 6.80 | 455 |

*Other F.S. ranges can be specified

DP/DS PANEL METER/DISPLAY OPTION

Digital panel meter installed on transmitter
 Power Supply: Loop Powered
 Display: 4 1/2 Digit LED, 0.6"
 Case: NEMA 4X
 Versions: DP Option: Displays 0-100% F.S
 DS Option: Scaled to customer requirement



ORDERING INFORMATION ORDER NUMBER (ABCDEF)

Example: CSLFB10NPTGBR8C

| A Model | B Pipe Thread | C Units of Measure | D Transducer Seal | E Options | F Transmitter Connector Option |
|--|---|--|--|--|--|
| CSLFB34 CSLFB10 CSLFB15 CSLFB20 | NPT= Female NPT BSP=Female British Standard Pipe (G) | G= Gallons Per Minute (U.S.) L= Liters Per Minute | E= EPDM B= Buna-N N= Neoprene® V= FKM | = None DF= Direction of flow output option R=100 OhmPlatinum RTD DP=Display % F.S DS=Display in Engineering Units- specify | = 1/2" NPT 4R= 4-Pin Male Circular Receptacle 8R= 8-Pin Male Circular Receptacle 4C= 4-Pin Female Circular Connector 8C= 8-Pin Female Circular Connector 4H=Hirschmann 4-conductor 1/2" NPT Receptacle (factory installed, female 1/2" NPT connector supplied for field wiring) |

*For non-listed ranges specify model followed by full span value
 Example: CSLFB15-50G = 50 GPM at 20 mA or CSLFB15-200L=200LPM @ 20 mA

ULTEM® is a registered trademark of The General Electric Company
 Neoprene® is a registered trademark of DuPont Dow

Clark reserves the right to make design changes without prior notice.