



Liquid Ultrasonic Flow Transmitters

Loop Powered 4-20 mA Output, Flows to 3000 GPM, 3" to 10" Pipe, Carbon Steel

DESCRIPTION

Clark Sonic® Ultrasonic Flowmeters are ideal for measurement of flow rates of acoustically conductive liquids including most clean liquids and many liquids with entrained solids.

Main advantages include excellent long term stability, no pressure drop, broad fluid compatibility, high accuracy and low cost. Also, there are no moving parts.

At the heart of the transmitter is a proprietary mixed signal ASIC which allows sophisticated timing, control and transducer drive circuitry to be combined on a single integrated circuit. The ASIC uses a special algorithm that is an improvement upon the standard single-path measurement technique. Using the "sing around" method, the ultrasonic transducer alternates between transmitting and receiving to measure differences in flight time between upstream and downstream transmissions. A sound pulse is transmitted from an upstream transducer towards a downstream transducer like a traditional time-of-flight measurement. However, the received sound pulse then triggers a second downstream transmission that then triggers a third and so on for a specific number of cycles. This process is repeated in the upstream direction.

Because it takes an average flight time over multiple cycles to compute the difference in flight times, the approach yields a significant improvement in timing accuracy when compared with the time-of-flight difference of a single sound pulse in each direction. This algorithm, combined with the pico-second timing resolution of the ASIC, provides the precise time measurement capability necessary for compact, small diameter ultrasonic meters.

The output of the transmitter is unaffected by changes in fluid temperature, density and viscosity as the flow calculation is independent of the speed of sound.

Wetted materials include ULTEM® encapsulated ultrasonic transducers with a choice of elastomer seals and epoxy coated carbon steel body material.

SPECIFICATIONS

GENERAL

Flow Range: Bi-directional, field selectable per "Standard Models" table

Accuracy: ±0.75% of full scale

Operating Temperature: -40 to 190°F (-40 to 87.8°C)

Response Time: User selectable, 2 or 10 seconds

Viscosity Range: 0.2 to 150 cSt (0.2 to 150 mPas)

Liquid Density: 30.6 to 74.9 lb/cu.ft. (490 to 1200 kg/m³)

Max. Working Pressure: 200 PSI (13.8 bars)

Pipe Sizes: 3", 4", 6", 8", 10"

Pipe Connections: ASME class 150 flange

Electrical Enclosure: Integral to Body casting with gasketed cover; One 1/2" NPT conduit connection (plugged when model ordered with metric threads) and one M16 x 1.5 connection (plugged when model ordered with NPT threads)

Electrical Connections: Screw terminal connections on PC board

Enclosure Rating: NEMA 4 (IP 65)

Power Supply: 18 to 36 VDC

WETTED MATERIALS

Ultrasonic Transducers: ULTEM® Encapsulated

Seals: EPDM, Buna-N, Neoprene™, FKM, or other

Body Material: Schedule 40, epoxy coated, carbon steel pipe



OUTPUT

Analog: 2-wire, 4-20 mA output; Output is 4 mA from zero to min. flow (see Standard Model table)

Error Detection: An optically isolated sink output is activated under certain detectable fault conditions, such as transducer failure or overly noisy output due to flow stream anomalies, as might be seen due to excessive bubble entrainment. The optional Fault output is an optically isolated NPN transistor capable of sinking up to 25 mA from a voltage source of no more than 48 VDC.

Direction of Flow: Optional output to indicate direction of flow is available. Activation or deactivation of an optically isolated 25 mA sink output indicates flow direction. Error detection is not available when this option is ordered.

Optional Temperature Sensor: 3 wire RTD, 100 Ohm, Platinum, Class A, IEC60751, built in to transducer shell for monitoring process temperature; optional 4 or 8 pin electrical connector recommended with this option

STANDARD MODELS

Model	Pipe Size	*Field Selectable Full Scale Ranges (GPM)		*Field Selectable Full Scale Ranges (LPM)		
		Min.	Max.	Min.	Max.	
CSLFC3	3"	L	3.0	200	11.0	750
		H	6.0	400	23.0	1500
CSLFC4	4"	L	4.5	300	17.0	1150
		H	7.5	500	29.0	1900
CSLFC6	6"	L	9.0	600	35.0	2300
		H	18.0	1200	68.0	4500
CSLFC8	8"	L	15.0	1000	57.0	3800
		H	30.0	2000	114	7600
CSLFC10	10"	L	22.5	1500	86.0	5700
		H	45.0	3000	165	11000

*F.S. ranges can be user specified to 125% of each stated high (H) range with no change to specifications and to 25% of each low (L) range with some specification modification.

DIMENSIONS

Pipe Size	Dimensions (Inches)						Bolt Circle Diameter	Number of Holes
	A	B	C	D	E	F		
3"	11.00	7.50	3.50	6.54	2.62	0.75	6.00	4
4"	13.00	9.00	4.00	6.54	2.62	0.75	7.50	8
6"	16.00	11.00	5.09	6.54	2.62	0.88	9.50	8
8"	18.00	13.50	6.11	6.54	2.62	0.88	11.75	8
10"	22.00	16.00	7.18	6.54	2.62	1.00	14.25	12

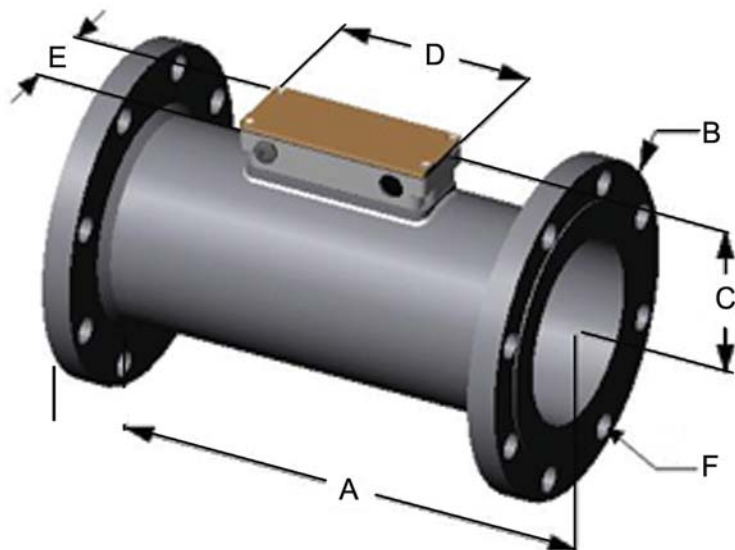

3" to 10" Schedule 40 Carbon Steel Pipe, ASME 150

ELECTRICAL

4-20 mA and NPN Opto-Isolated Fault Output

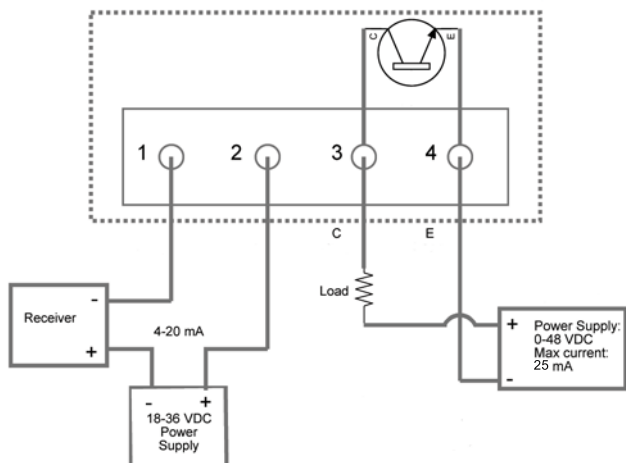

LOOP RESISTANCE Vs SUPPLY VOLTAGE

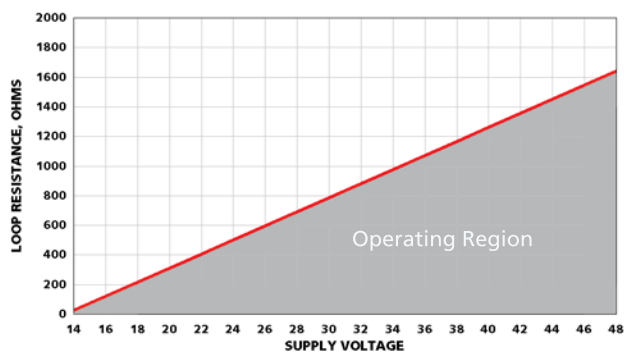

FIELD SERVICE

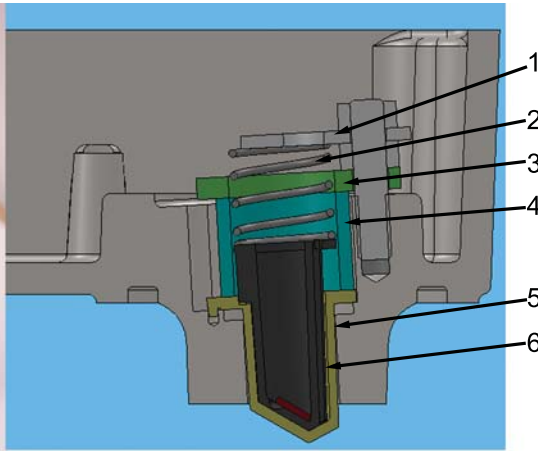
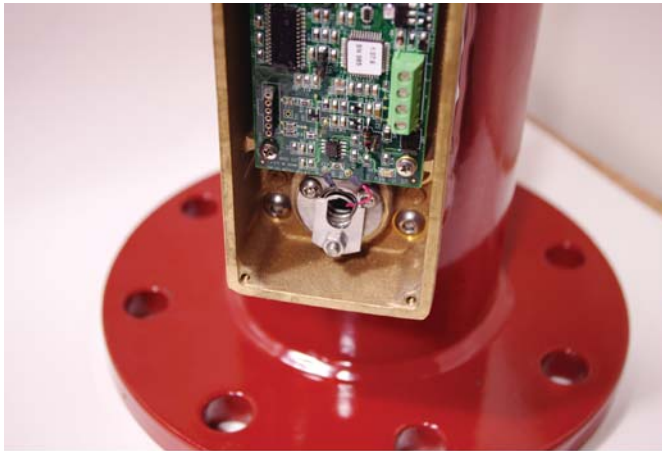

Two opposing CSLFC ultrasonic transducers are inserted into fixed ULTEM® drywells and held in place with light spring force. A locating keyway in the drywell aids insertion and positioning of the transducers. In the event of field failure of a transducer, replacement is straightforward and can be accomplished without removing the pipe spool and shutting down the process.

The electrical PC board can also be field replaced. Calibration factor and other specific information are maintained at the factory for all transmitters shipped.

Transducer Components	
1	Spring Retainer
2	Spring
3	Clamp
4	Bushing
5	Drywell
6	Ultrasonic Transducer

DP/DS PANEL METER/DISPLAY OPTION

Digital panel meter installed on transmitter

Power Supply: Loop Powered

Display: 4 1/2 Digit LED, 0.6"

Case: NEMA 4X

Versions: DP Option: Displays 0-100% F.S

DS Option: Scaled to customer requirement



Panel Meter/
Display option

Four or eight pin
receptacle connector
recommended

ORDERING INFORMATION

ORDER NUMBER (ABCDE)

Example: CSLFC10GB

A Model	B Units of Measure	C Transducer Seal	D Options	E Transmitter Connector Option
CSLFC3 CSLFC4 CSLFC6 CSLFC8 CSLFC10	G= Gallons Per Minute (U.S.) L= Liters Per Minute	E= EPDM B= Buna-N N= Neoprene® V= FKM	= None DF= Direction of flow output option R=100 OhmPlatinum RTD DP=Display % F.S DS=Display in Engineering Units	= 1/2" NPT 4R= 4-Pin Male Circular Receptacle 8R= 8-Pin Male Circular Receptacle 4C= 4-Pin Female Circular Connector 4C= 4-Pin Male Circular Connector 4H=Hirschmann 4-conductor 1/2" NPT Receptacle (factory installed, female 1/2" NPT connector supplied for field wiring)

*For non-listed ranges specify model followed by full span value
Example: CSLFC4-150G = 150 GPM at 20 mA or CSLFC4-750L=750LPM @ 20 mA

ULTEM® is a registered trademark of The General Electric Company

Neoprene® is a registered trademark of DuPont Dow



Optional NEMA 4 four or eight-pin receptacles installed in transmitter conduit connection and factory wired along with mating circular connectors simplify field installation



4H-Hirschmann Connector