

HUBA**699 Series Differential Pressure Indicator & Transmitter***Field Selectable Voltage and Current Outputs, F.S. Ranges From 0.1 to 20 "***DESCRIPTION**

Series 699 measures low differential pressures typically found in air conditioning applications such as air flow measurement, fan static pressures and specialty room pressure measurements in clean rooms and other low pressure space monitoring applications.

The 699 series incorporates time proven ceramic fulcrum lever technology. They deliver adjusted and temperature-compensated sensor signals, available as standard voltage or current outputs.

The 699 is available in three configurations offering different levels of function and cost.

Configuration 1 is a transmitter with field selectable ranges and factory preset output signal and zero offset configurations.

Configuration 2 incorporates a 10 position DIP switch allowing field selection of range, output signal & response time. A potentiometer allows further adjustment of span within the selected range.

Configuration 3 incorporates an LED display and full field function programming via programming button including setting of range and fine tuning of span, output signal, zero offset, units of measurement, response time, square root extraction and display light settings.

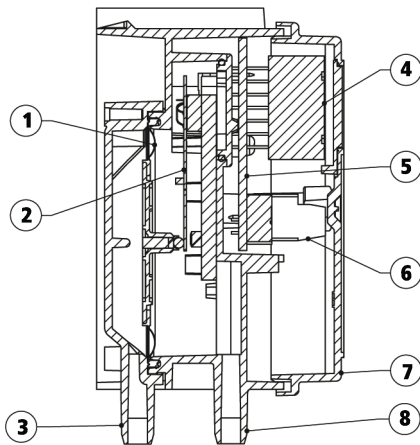
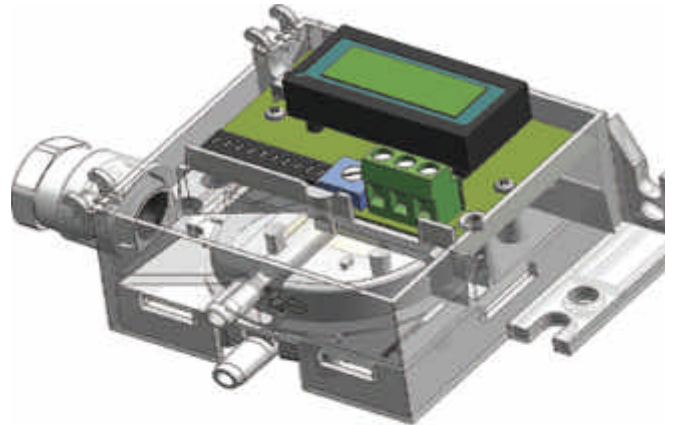

Cross-section Drawing Legend	
1	Diaphragm
2	Sensor element
3	P1(Higher Pressure) Pressure connection
4	LCD-Display (option)
5	Amplification Circuit
6	Connection terminals
7	Cover
8	P2 (Lower Pressure) Pressure connection

SPECIFICATIONS

Medium: Air and neutral gases

Pressure ranges: F.S. from ± 0.1 to 20" w.c.

See order table for field selectable ranges offered for each model

Units of pressure measurement: Inches w.c., mm w.c.

Tolerable overload on one side of diaphragm:

Pressure: 40" w.c. at P1, 1.6" w.c. at P2

Vacuum: 40" w.c. at P2, 1.6" w.c. at P1

Rupture pressure:

2 x overload at ambient temperature

1.5 x overload at 70 °C

Zero Adjustment: Zero point resettable by reset button

Materials in contact with medium:

Housing: Polycarbonate PC

Diaphragm: Silicone

Sensor: Al₂O₃ (96%) / glass

Temperature:

Medium and ambient: 32 to 158°F (0 to +70 °C)

Storage: 14 to 158°F (10to +70 °C)

No condensation

Output/Power Supply:

Three-Wire

0 to 10 V, 13.5 to 33 VDC / 24 VAC $\pm 15\%$

0 to 20 mA, 13.5 to 33 VDC / 24 VAC $\pm 15\%$

4 to 20 mA, 13.5 to 33 VDC / 24 VAC $\pm 15\%$

Two-Wire

4 to 20 mA, 8.0 to 33 VDC

SPECIFICATIONS

Output/Power Supply (Cont'd):
 Additional adjustable by software (with LCD-
 Display, configuration 3 only): 0-5.0V, 6.5 to
 33 VDC / 24 VAC ±15%

Load:
 3-wire:
 0-10 V > 10 kOhm
 0-20 mA < 500 Ohm
 4-20 mA < 500 Ohm
 2-wire:
 4-20 mA < $\frac{\text{supply voltage} - 8 \text{ V}}{0.02 \text{ A}}$ Ohms

Current Consumption:
 3-wire:
 0-10 V < 10 mA
 0-20 mA < 30 mA
 4-20 mA < 30 mA
 2-wire:
 4-20 mA 20 mA
 Backlight LCD-Display: 30 mA

Dynamic response:
 Response time: < 20 ms
 Load cycle: < 10 Hz
 Response time Filter: Filter response time switchable
 for configuration 2: off or 1 second

Filter response time programmable for
 configuration 3: 0.2 / 1 / 5 / 20 seconds
 Electrical connection: Screw terminals for wire and
 stranded conductors up to 16 AWG, PG11 cable
 gland with built-in strain relief
 Polarity reversal protection: Short circuit proof and
 protected against polarity reversal. Each
 connection is protected against crossover up to
 max. supply voltage.
 Protection standard:
 Without cover: IP 100
 With cover: IP 54 or IP 65
 Pressure connections:
 Hose barb: .244" (6.2 mm)
 Installation: Recommended and factory adjustment
 vertical, with pressure connections downward
 Mounting: Mounting bracket (integrated in case)
 Display, configuration 3: LCD display, double spaced
 per 8 digit alphanumeric (3-wire with backlight)
 Tests: CE conform
 Weight:
 With Display: approx. 100 g
 Without Display: 90 g
 Packaging: Individually boxed

Accuracy					
	0.2" w.c.	0.4" w.c.	1.2" w.c.	2.0" w.c.	4 to 20" w.c.
Tolerance zero point (max.)	±1.0% fs	±1.0% fs	±0.7% fs	±0.7% fs	±0.7% fs
Tolerance full scale	±1.0% fs	±1.0% fs	±0.7% fs	±0.7% fs	±0.7% fs
Resolution	±0.2% fs	±0.2% fs	±0.1% fs	±0.1% fs	±0.1% fs
Total of linearity, hysteresis and repeatability (max.)	±1.0% fs	±1.0% fs	±1.0% fs	±1.0% fs	±0.6% fs
Long term stability acc. to DIN IEC 60770	±1.0% fs	±1.0% fs	±1.0% fs	±1.0% fs	±1.0% fs
Temp. Coeff. zero point (typ.)	±0.2% fs/10K	±0.2% fs/10K	±0.2% fs/10K	±0.1% fs/10K	±0.1% fs/10K
TC Temp. Coeff. zero point (max.)	±1.0% fs/10K	±1.0% fs/10K	±0.5% fs/10K	±0.4% fs/10K	±0.4% fs/10K
Temp. Coeff. sensitivity (typ.)	±0.3% fs/10K	±0.3% fs/10K	±0.2% fs/10K	±0.1% fs/10K	±0.1% fs/10K
Temp. Coeff. sensitivity (max.)	±0.6% fs/10K	±0.6% fs/10K	±0.5% fs/10K	±0.5% fs/10K	±0.2% fs/10K

Test conditions: 25 °C, 45%RH, Power Supply 24 VDC; Temperature Coefficient Zero Point 32 to 158°F (0 ... 70 °C)

PRESSURE RANGE ZERO OFFSETS Factory preset for configurations 1 & 2; Field programmable for configuration 3

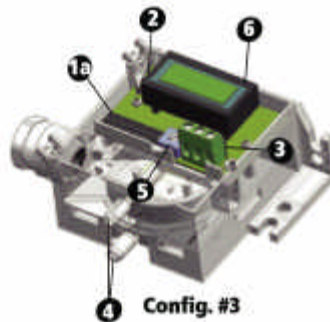
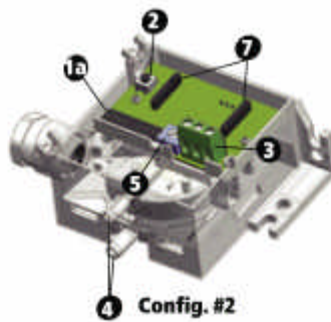
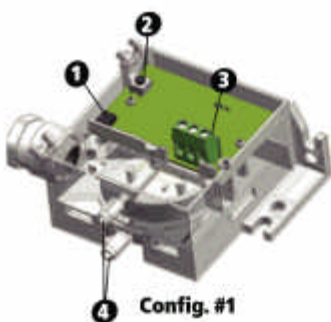
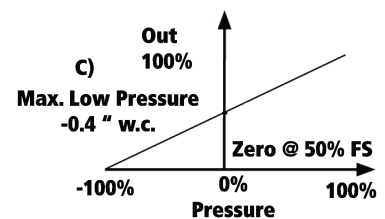
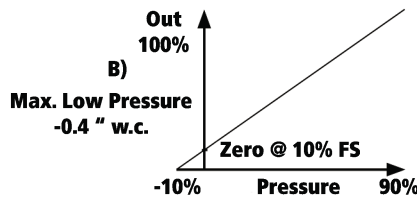
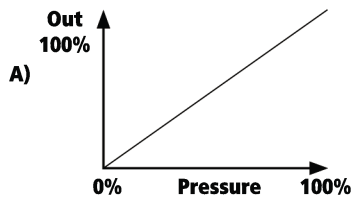

Legend	
1	Dual DIP Switch
1a	10 Position DIP Switch
2	Zero Point Reset
3	Terminal Connection
4	P1 & P2 Pressure Ports
5	Signal Amplification Potentiometer
6	LCD
7	LCD Receptacle

Configuration Major Differences			
Parameter	Config. 1	Config. 2	Config. 3
LCD Display	No	No	Yes
Field Select Output Signals	No	Yes	Yes
Field Select Response Time	No	Std. or 1 sec.	0.2, 1, 5 or 20 sec.
Display Program Menu & Program Button	No	No	Yes

Dimensions mm

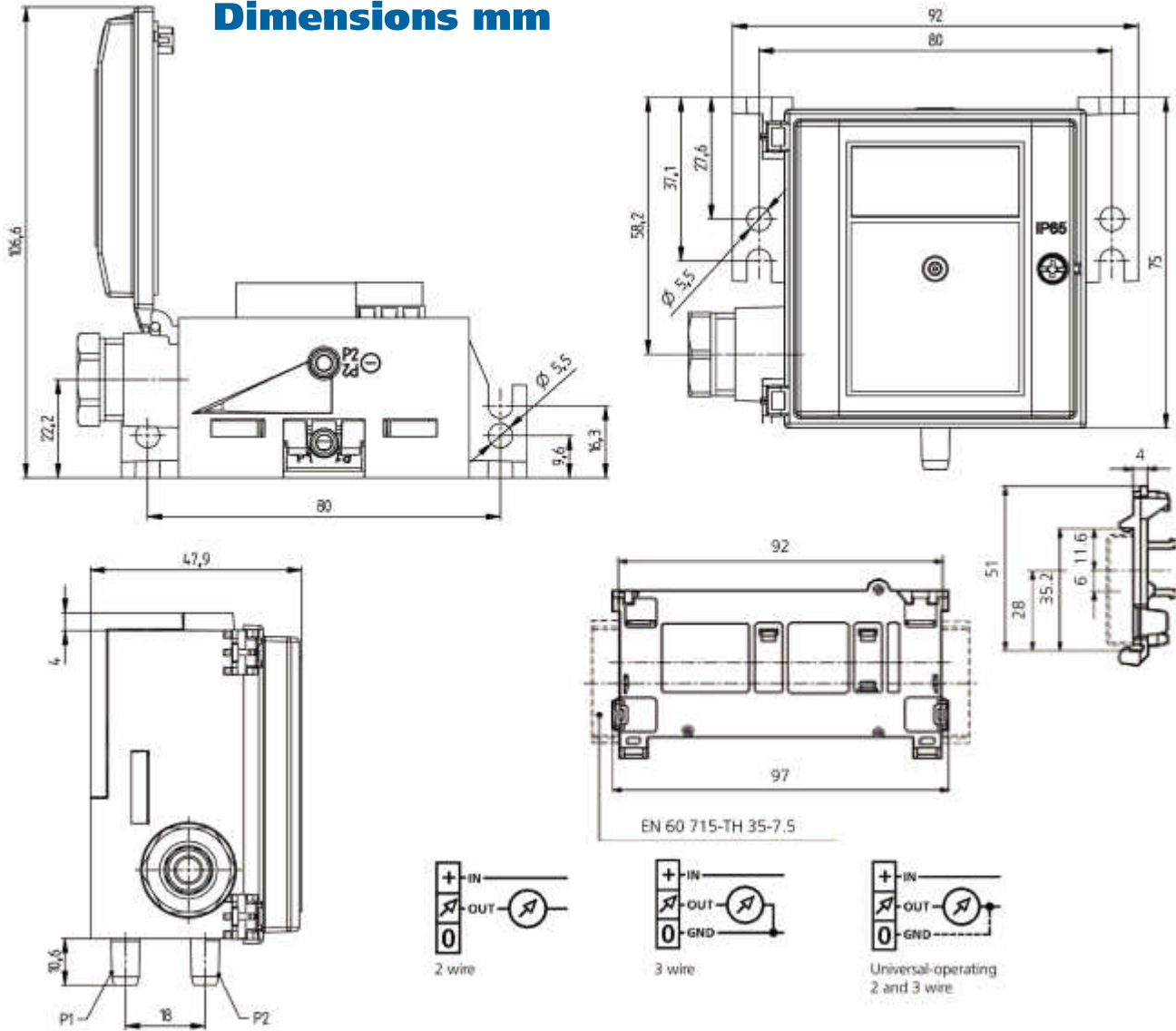

ORDERING INFORMATION A-BCDEFGHI (6999-11321113)

A Model	B Pressure Range Zero Offset	C F.S. Pressure Range Field Selectable as Designated	D Units of Measure	*E Output Signal/ Adjustment	F Output & Power Supply	**G Display
6999	1= 0-100% 2= -10% to 0 to 100% 3= -100% to 0 to +100%	0= 0.1/0.2 inches w.c. 1= 0.1/0.2/0.3 inches w.c 2= 0.3/0.6/1 inches w.c 3= 0.5/1/2 inches w.c 4= 1/2/3 inches w.c 5= 2/3/5 inches w.c 6= 3/5/10 inches w.c 7= 5/10/20 inches w.c	3= inches of water 6= mm w.c	1= Linear w/o filter 2= Linear w/ filter (Config 2&3) 4= Square root extracted w/o filter 3= Square root extracted w/filter (Config 2&3)	1= 0-10 V, three-wire 2= 0-20 mA- three-wire 4= 4-20 mA, three-wire 5= 4-20 mA, 2-wire	0= None 1= In Eng. Units Ordered 2= In % F.S.

*For Configuration 2 Select Output Signal 2 or 3 ** For Configuration 3 Select Display 1 or 2

H Connection	I Environmental
1= 6.2 mm Tube Connection 2= 6.2 mm Tube Connection, Orifice in P1 3= 6.2 mm Tube Connection, Orifice in P2 4= 6.2 mm Tube Connection, Orifice in P1 & P2	0= IP54 3= IP65