

## VERDER M1500 Peristaltic Pump

Flow Rate To 1.6 l/min (26 GPH)

### DESCRIPTION

Model M1500 is a rugged, dependable pump utilizing thick wall tubing for improved performance on viscous fluids. It has considerable suction lift ability.

The pump is typically used for chemical dosing, vending machines, crop spraying and other fluidic applications.

### SPECIFICATIONS

Pump Head: Black cycloloy with support bearing

Front Cover: Clear polycarbonate with 3 mounting screws

Rotor: 2 roller design, Nylon 6, with Acetal polymer rollers

Motor: Permanent magnet 12Vdc or 24Vdc

Power Consumption- 30 watts

Gearbox Speeds: 82 RPM, 125 RPM, 176 RPM

Tube: Thick wall (2.4 mm) round sections Silicone & Verderprene, 6.4 mm and 8 mm I.D.;

Polypropylene tube connectors provided.

Weight: 1.8 kgs (4.0 lb)



### Free Flow Curve

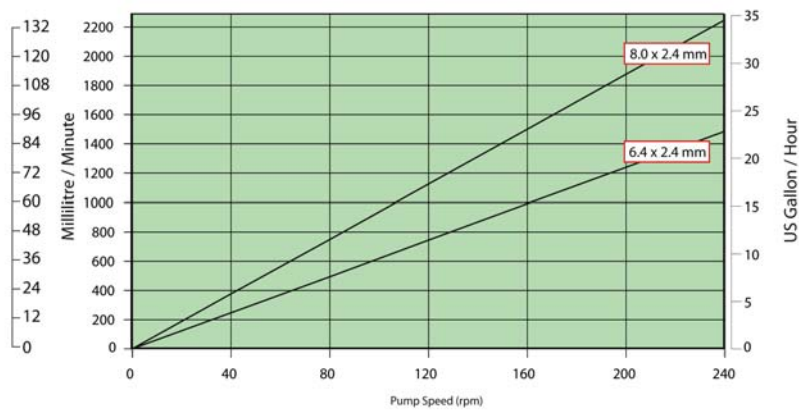

### Suction

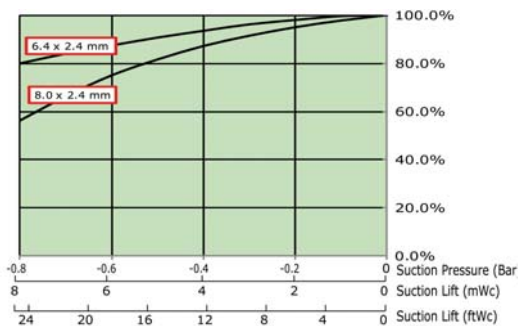

### Discharge

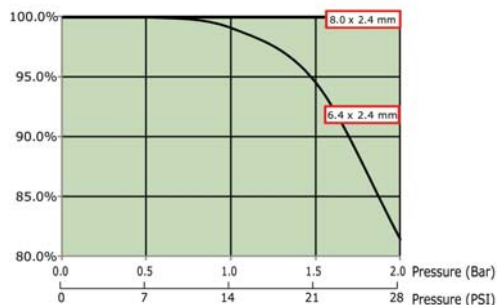

## DIMENSIONS (MM, INCHES)

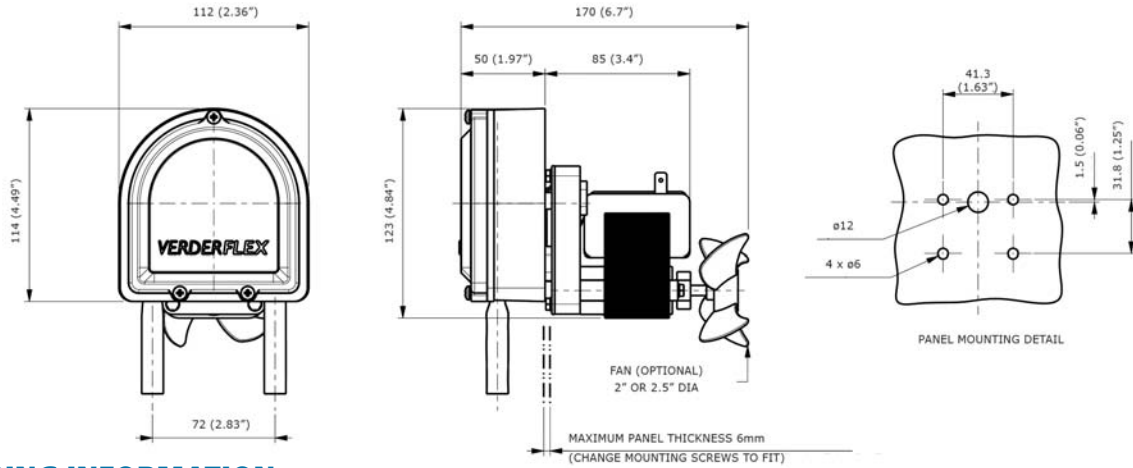

## ORDERING INFORMATION

Pump Part Number Selection Table				
Speed (rpm)	Motor Voltage	Tube Material	Tube Size (ID)	Part Number
82	12V DC	VERDERPRENE	6.4 mm	AU R1560082 05
			8 mm	AU R1580082 12
		SILICONE	6.4 mm	AU R1560082 07
			8 mm	AU R1580082 02
	24V DC	VERDERPRENE	6.4 mm	AU R1560082 03
			8 mm	AU R1580082 04
SILICONE	6.4 mm	AU R1560082 04		
	8 mm	AU R1580082 13		
125	24V DC	VERDERPRENE	6.4 mm	AU R1560125 06
			8 mm	AU R1580125 08
176	12V DC	VERDERPRENE	6.4 mm	AU R1560176 06
			8 mm	AU R1580176 18
		SILICONE	6.4 mm	AU R1560176 11
			8 mm	AU R1580176 25
	24V DC	VERDERPRENE	6.4 mm	AU R1560176 04
			8 mm	AU R1580176 07
		SILICONE	6.4 mm	AU R1560176 07
			8 mm	AU R1580176 19

Replacement Tubing			
Part Number	Tube Material	Tube I.D.	Description
150.0623.1	VERDERPRENE	6.4 mm	1 MTR LENGTH VERDERPRENE 6.4 ID x 2.4 WT
150.0623.15			15m ROLL VERDERPRENE 6.4 ID x 2.4 WT
150.0626.1		8 mm	1 MTR LENGTH VERDERPRENE 8.0 ID x 2.4 WT
150.0626.15			15m ROLL VERDERPRENE 8.0 ID x 2.4 WT
460.1032.1	SILICONE	6.4 mm	1 MTR LENGTH SILICONE TUBE 6.4 IDx2.4 WT
460.1032.15			15m ROLL SILICONE TUBING 6.4 ID x 2.4 WT
460.0705.1		8 mm	1 MTR LENGTH SILICONE TUBE 8.0 IDx2.4 WT
460.0705.15			15m ROLL SILICONE TUBING 8.0 ID x 2.4 WT

Spare Parts	
Part Number	Description
AU E1137 02	M1500 2R ROTOR ASSEMBLY
AU E1138	M1500 STANDARD HOUSING
AU E1138 02	M1500 ROBUST DC MOTOR HOUSING
AU E1139	M1500 FRONT COVER
AU E0017	BALL RACE BRG 3/8" ID x 7/8" OD
AU E0037	FAN : COUNTER CLOCKWISE, NYLON
185.1035.P	PK 10 8/10 MM WHT ACETAL TUBE CONNECTORS
185.1034.P	PK 10 8/10MM BLACK PP TUBE CONNECTORS