

# VERDER M2000 Peristaltic Pump

Flow Rate To 1.4 l/min (22.6 GPH)

## DESCRIPTION

Model M2000 is the larger of a two pump group featuring a unique and patented quick-change tube loading system. The tube cartridge can be changed easily by unclipping from the pumphead and replacing with a new cartridge.

Tube creep is eliminated through use of dove tail sectioned tubing ultrasonically welded to the tube cartridge.



## SPECIFICATIONS

Pump Head: Black polycarbonate with support bearing and mounting plate  
 Rotor: Polycarbonate, 316 stainless steel inserts with Nylatron® rollers  
 Motor: 24V D.C., 30W

Tube:  
 Verderprene: 8mm tube/cartridge assy  
 Silicone: 8mm tube cartridge assy  
 Tube Sizes (I.D x Wall Thickness): .8.0 x 1.9mm  
 Weight: 1.8 kg (4.0 lb)

Free Flow Curve

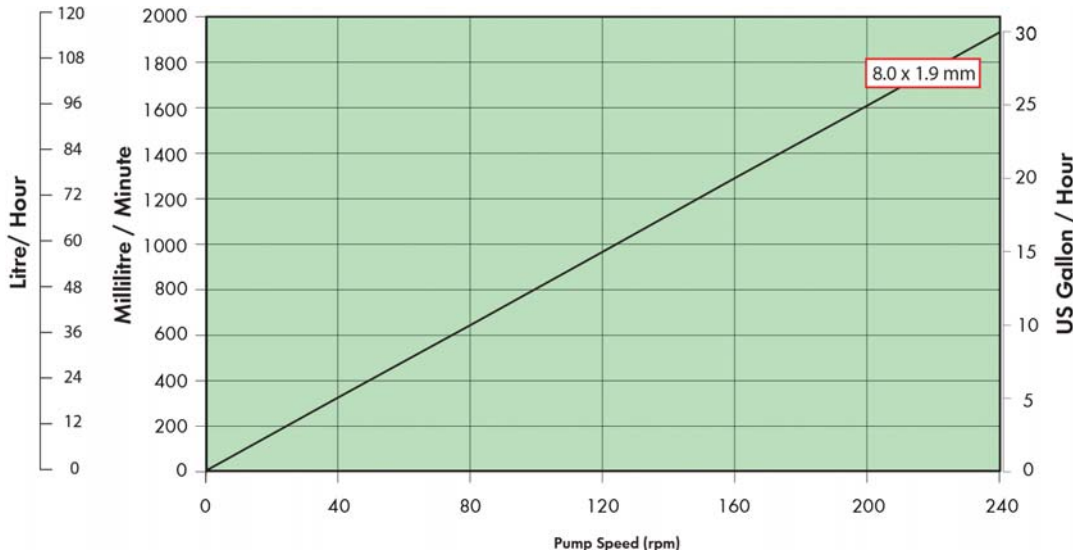

Suction

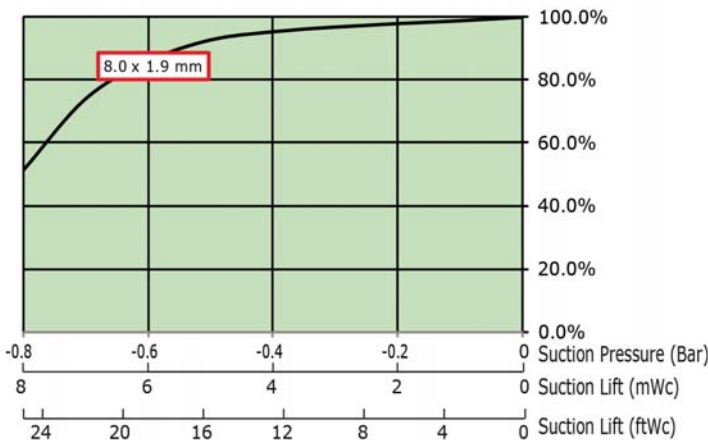

Discharge

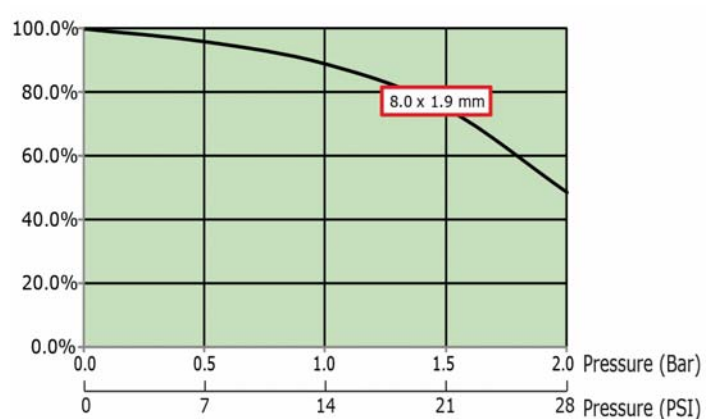

## DIMENSIONS (MM, INCHES)

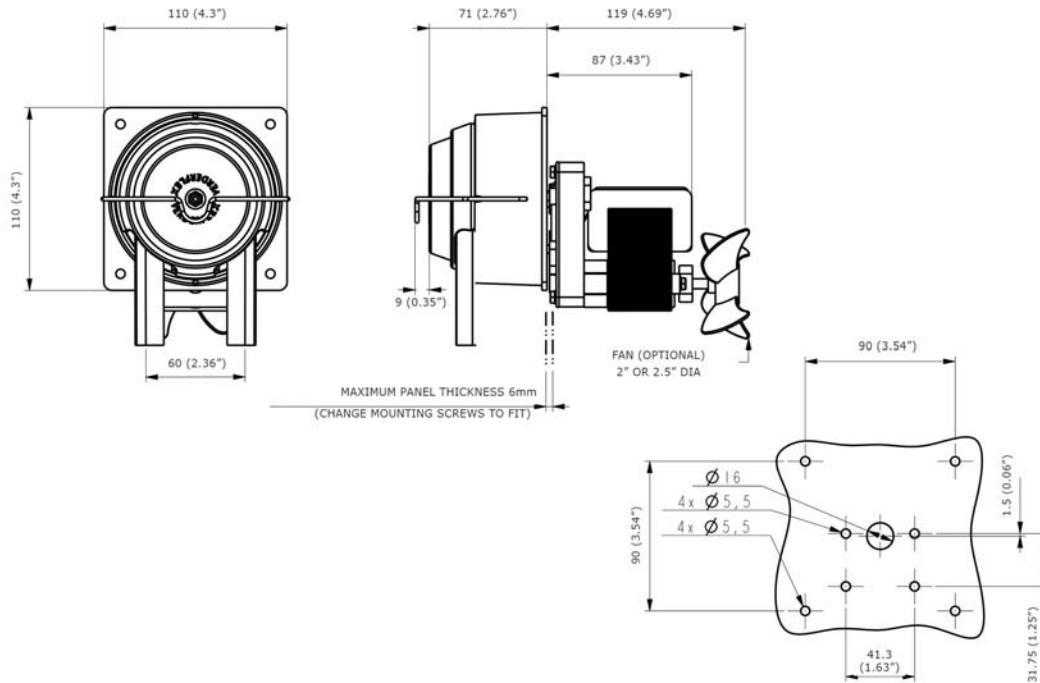

## ORDERING INFORMATION

Pump Part Number Selection Table- Part number Includes Pump, Motor & Tube Cartridge				
Speed (rpm)	Motor Voltage	Tube Material	Tube Size (ID)	Part Number
30	24V DC	VERDERPRENE	8 mm	AU M280085 14
		SILICONE	8 mm	AU M280085 16
125		VERDERPRENE	8 mm	AU M280125 26
		SILICONE	8 mm	AU M280125 02
176		VERDERPRENE	8 mm	AU M280176 17
		SILICONE	8 mm	AU M280176 15

Replacement Tubes Cartridge Assemblies			
Part Number	Tube Material	Tube I.D.	Description
AU E0048 2CPA 08 P	VERDERPRENE	8 mm	PACK OF 5 M2000 8MM VERDERPRENE CARTRIDGES
AU E0048 2CPS 08 P	SILICONE	8 mm	PACK OF 5 M2000 8MM SILICONE CARTRIDGES

Spare Parts	
Part Number	Description
AU E0075 03	M2000 HOUSING
AU E0074	M2000 POLYCARBONATE BACKPLATE
AU E0076 03	M2000 ROTOR ASSEMBLY
AU E0017	BALL RACE BRG 3/8" ID x 7/8" OD
AU E0080	M2000 CARTRIDGE RETAINING CLIP
AU E0037	FAN : COUNTER CLOCKWISE, NYLON
185.1034.P	PK 10 8/10MM BLACK PP TUBE CONNECTORS
185.1035.P	PK 10 8/10 MM WHT ACETAL TUBE CONNECTORS
AU E0066	M2000 ROTOR SETTING JIG - 8MM TUBE