

## DEBEM

# Model MID Air Operated Diaphragm Pump

Flow Rates to 5 LPM (1.32 GPM), Pressure to 70 Meters (99.7 PSI)

### DESCRIPTION

MID mini diaphragm pumps are characterized by exceptional performance, power and strength, making them ideal for pumping liquids with very high apparent viscosity up to 50000 cps (at 20°C), even if containing suspended solids.

The stall-prevention pneumatic system assures a safe running pump and it does not require lubricated air. Self-priming dry capacity even with considerable suction head, fine tuning of speed without pressure loss and the possibility of dry operation without suffering damage mean that these pumps offer unrivalled versatility.

In addition, the huge choice of construction materials allows selection of optimum chemical compatibility with the fluid and/or environment without neglecting the temperature range.

They are specifically designed for demanding applications with high humidity or in potentially explosive atmospheres (ATEX certification).



### SPECIFICATIONS

- Pump Body Materials: PP (Polypropylene)
- Intake/delivery connections: 1/4" NPT Female
- Air Connection: 1/8" NPT Female
- Max. Self-Priming Capacity: 3 meters (9.84 ft)
- Max. Flow Rate: 5 l/min ( 1.32 GPM)
- Max. Head: 70 m (99.7 PSI)
- Max. Air Supply Pressure: 7 bar (102 PSI)
- Max. Diameter of Passing Solids: 0 mm (0")
- Net Weight: 0.5 Kg (1.1 lbs)
- Max Temperature: PP, 60°C (140°F)
- ATEX Ratings:

STANDARD version: Made from non-conductive plastic and/or with non-conductive centre casing or from metal with non-conductive centre casing.  
ATEX Classification Ⓜ II 3/3 GD c IIB T135°C (for zone 2)

CONDUCT version: Built with pump casings and/or manifolds (PP + carbon fiber), made from conductive plastic. Ⓜ II 2/2 GD c IIB T135°C (for zone 1)

### FLOW CURVES

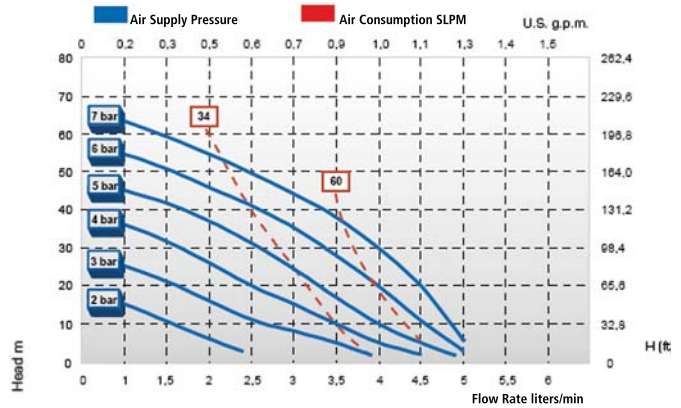

The curves and performance values refer to pumps with submerged suction and a free delivery outlet with water at 20°C, and vary according to the construction material.

### DIMENSIONS (MM)

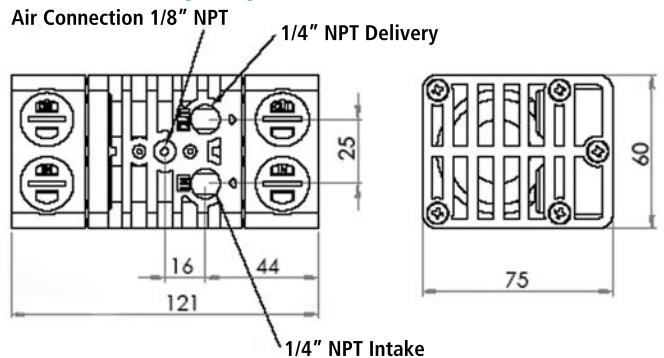

### ORDERING INFORMATION

#### ABCDEFGH

Example: MIDPNTGRT

A Model	B Pump Body	C Air Side Diaphragm	D Fluid Side Diaphragm	E Balls	F Ball Seats	G O Rings	H Options
MID	P= Polypropylene	N= NBR	T= PTFE	G= Pyrex Glass	R= PPS-V K= PEEK (Use for Hydrogen Peroxide)	T= PTFE	= None C= CONDUCT ATEX Rating