

# CLARK Mono Oscillating Piston Pump

120 VAC, 0 to 95 LPH

## DESCRIPTION

This latest version of the "Mono" oscillating piston pump has been developed looking at the future. The hydraulic improvements make this pump the ideal component for applications where safety and reliability are necessary elements. The "Mono" oscillating piston pump, designed for pumping a range of fluids including potable water, food quality low viscous syrup and semi-aggressive fluids at relatively high pressures under continuous operation, is available with brass or plastic fittings, with glass or EPDM check valves and a AISI 430 or AISI 630 stainless steel piston.

The coil is made of self-extinguishing material with a class H insulation winding. All the models are equipped with a noise suppression device that allows installation of the pump in those applications where low noise is a premium. Shock absorbing supports are also available for the quietest operation.

## TYPICAL APPLICATIONS

- Espresso coffee machines
- Beverage vending machines
- Smoke generators
- Steam generators
- Carpet cleaners
- Water purifiers
- Water Carbonators

## SPECIFICATIONS

"IF" Coil(UL recognized, file E164244)

Voltage : 120 V

Frequency : 60 Hz

Power : 70 W

Current : 0.98 A

Seals: NBR

Inlet/Outlet Connections: 1/8" NPT brass

Flow: Dependent on piston size, see flow chart

Model 1106- 6mm piston

Model 1108- 8mm piston

Model 1110- 10mm piston

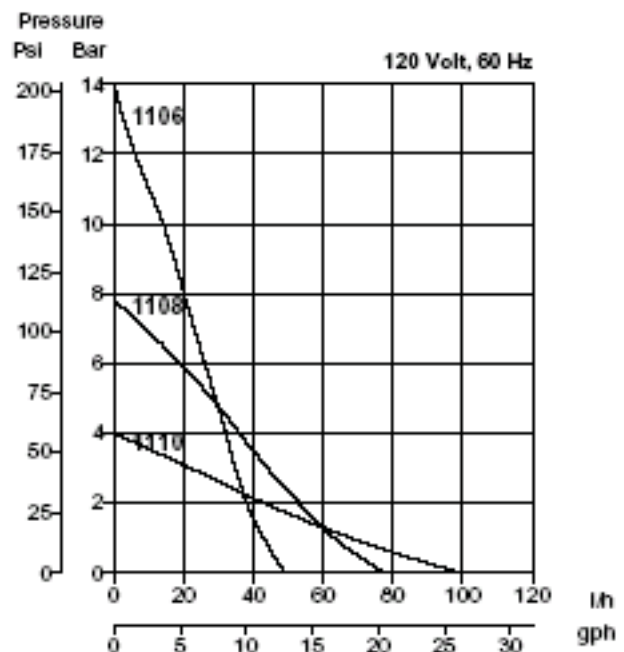
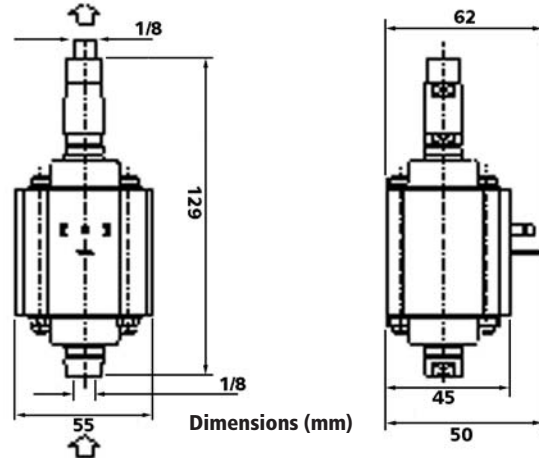
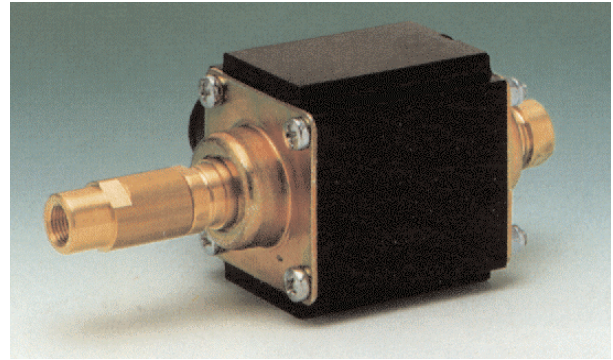

## ORDERING INFORMATION

Model	Description
1106RLIFM9N	6 mm Piston
1108RLIFM9N	8 mm piston
1110RLIFM9N	10 mm piston

