

# CLARK

## TM 30-200 Series Magnet Drive Rotary Vane Pump

Flow to 550 LPH, Pressure to 200 PSI

### DESCRIPTION

The principle of the magnet drive is the driving force of the pole-to-pole alignment of 2 magnets. The driven magnet is attached to the pump shaft within the pump, while the driving magnet is attached to the motor shaft and closely located to the driven magnet. By means of magnetic attraction, the pump rotates in response to motor shaft rotation.

This series of pumps is available in four different displacements. The housing is either brass or AISI 303 stainless steel with carbon graphite internal components. The pumps can be equipped with an optional built-in relief valve. Inlet and outlet ports have 3/8" NPT female threads. All models are available with NBR, Viton or EPDM seals. Compared to conventional coupling, the magnet drive has several advantages:

- 1) Immediate decoupling upon overload
- 2) Higher efficiency
- 3) Longer service life
- 4) No leaks or contamination
- 5) Noiseless operation

### SPECIFICATIONS

Pump Housing: Bras or AISI 303 Stainless Steel  
 Pumping Chamber: Carbon Graphite  
 Ports: 3/8" NPT  
 Max Temperature : 70° C (158° F)



### TYPICAL APPLICATIONS

- Solar heating systems
- Booster Systems
- Cooling systems
- Water Treatment



Seals: NBR (Viton, EPDM upon request)  
 Max Size Solid Particles : 10 microns  
 Max Motor Speed : 3600 rpm  
 Max System Pressure : 18 Bar (260 psi)  
 Pump Weight: 1.1 kg(2.4 lb)

### DIMENSIONS (MM)

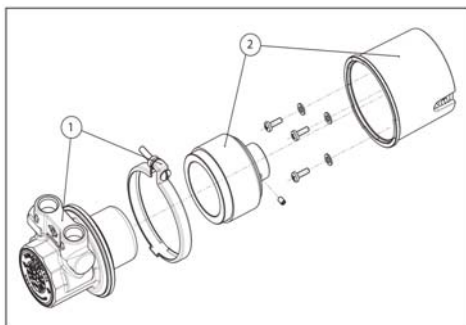
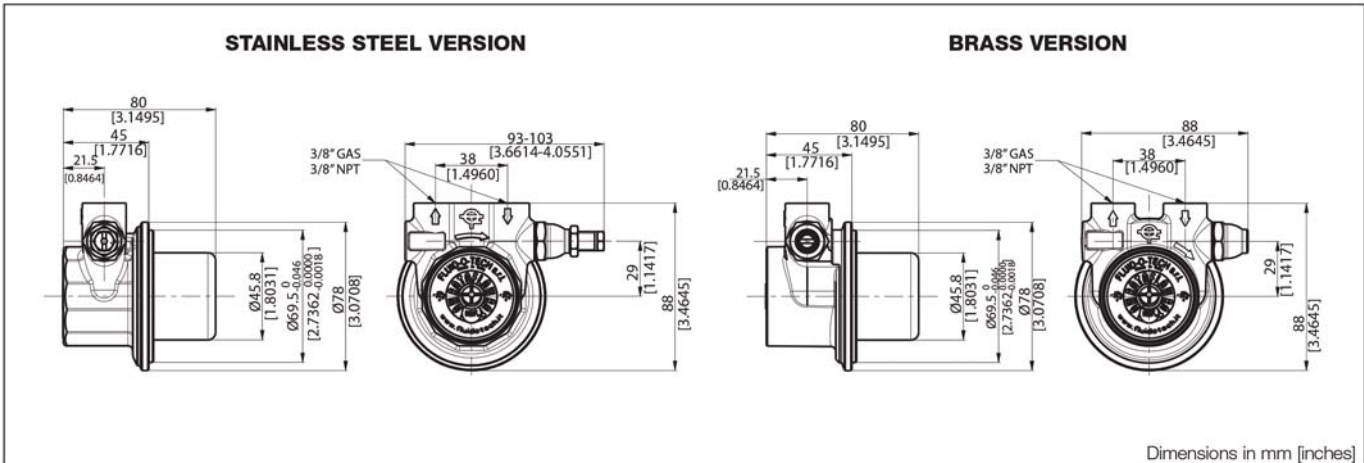

Table 1

Motor Adapter		
Position	Description	Part Number
1	TM Series Pump	Table 2
2	NEMA 56C Adaptor Assembly- includes P/N 201607 NEMA 56 Adapter & P/N TMAF5BS Driving Magnet 5/8"	TMB3

## ABOUT RELIEF VALVES

Relief valves are offered on select models of rotary vane pumps throughout the product line. Two types of relief valves are offered:

- 1) Standard Relief valve: A spring loaded bypass check valve diverts flow from the pump outlet to the pump inlet when outlet pressure exceeds setpoint (set with spring tensioning set screw).
- 2) Balanced relief valve: A pressure compensation plunger with dynamic seal and referenced (ported on one side) to atmosphere is added to the downstream side of the standard check-valve assembly. This insures that cracking pressure of the relief valve remains unchanged regardless of changes in inlet pressure (that might be a condition in a pressurized system).

The cracking pressure can be field set by adjusting the spring tension with the adjusting screw. If the cracking pressure is not customer specified it is factory preset at approximately 190 PSI for TM 30-200 series.

It is not recommended to use the relief/bypass valve for flow control. This will result in premature wear of the valve assembly and require frequent maintenance.

## MODEL SELECTION/FLOW CURVES

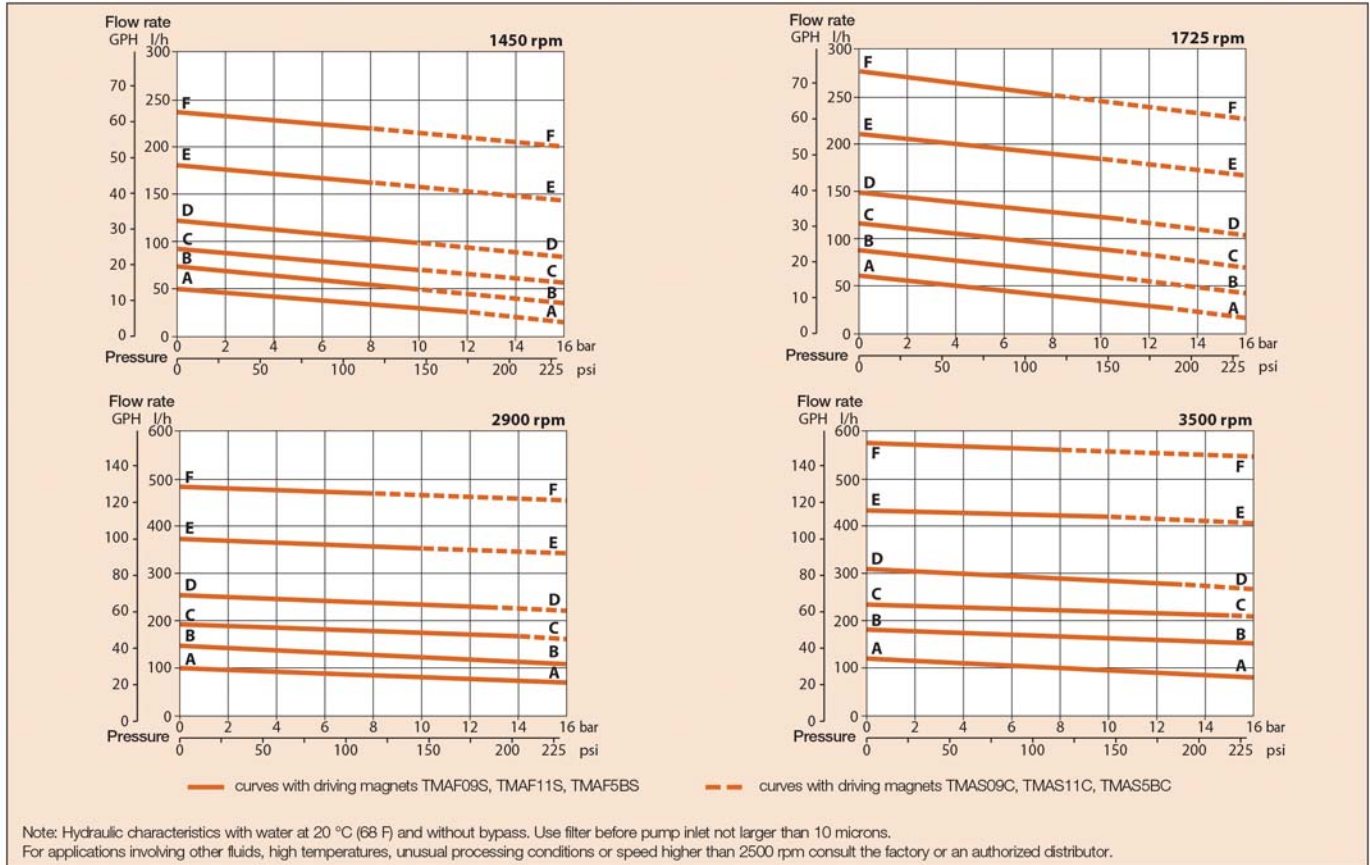

Table 2

Model	Relief Valve	Housing	Figure
TMSS030	No	Stainless Steel	A-A
TMSS050			B-B
TMSS070			C-C
TMSS100			D-D
TMSS150			E-E
TMSS200			F-F
TMSS031	Standard	Stainless Steel	A-A
TMSS051			B-B
TMSS071			C-C
TMSS101			D-D
TMSS151			E-E
TMSS201			F-F
TMOT030	No	Brass	A-A
TMOT050			B-B
TMOT070			C-C

Model	Relief Valve	Housing	Figure
TMOT100	No	Brass	D-D
TMOT150			E-E
TMOT200			F-F
TMOT031	Standard	Brass	A-A
TMOT051			B-B
TMOT071			C-C
TMOT101			D-D
TMOT151			E-E
TMOT201			F-F
TMOT034	Balanced	Brass	A-A
TMOT054			B-B
TMOT074			C-C
TMOT104			D-D
TMOT154			E-E
TMOT204			F-F