

CLARK

TM 300-400 Series Magnet Drive Rotary Vane Pump

Flow to 550 LPH, Pressure to 200 PSI

DESCRIPTION

The principle of the TM pump magnet drive is the driving force of the pole-to-pole alignment of 2 magnets. The driven magnet is attached to the pump shaft within the pump, while the driving magnet is attached to the motor shaft and closely located to the driven magnet. By means of magnetic attraction, the pump rotates in response to motor shaft rotation.

The TM 300-400 housing is AISI 303 stainless steel with carbon graphite internal components. The pumps can be equipped with an optional built-in relief/bypass valve. Inlet and outlet ports have 1/2" NPT female threads. All models are available with NBR, Viton or EPDM static seals. Compared to conventional coupling, the magnet drive has several advantages :

- 1) No Mechanical Seals
- 2) Totally Sealed Body
- 3) Longer service life
- 4) Low Power Consumption
- 5) Noiseless operation



TYPICAL APPLICATIONS

- Solar heating systems
- Refrigerating gas transfer
- Cooling systems
- Carpet cleaners



SPECIFICATIONS

Pump Housing: AISI 303 Stainless Steel
 Pumping Chamber: Carbon Graphite
 Ports: 3/8" NPT
 Max Temperature : 70° C (158° F)

Seals: NBR (Viton, EPDM upon request)
 Max Size Solid Particles : 20 microns
 Max Motor Speed : 1725 rpm
 Max System Pressure : 20 Bar (290 psi)
 Pump Weight: 1.0 kg(2.2 lb)

DIMENSIONS (MM)

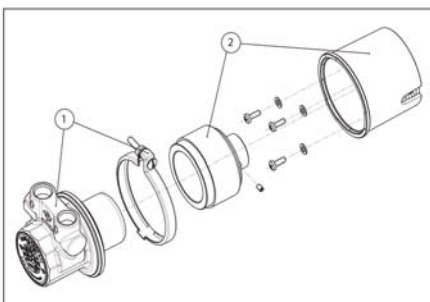
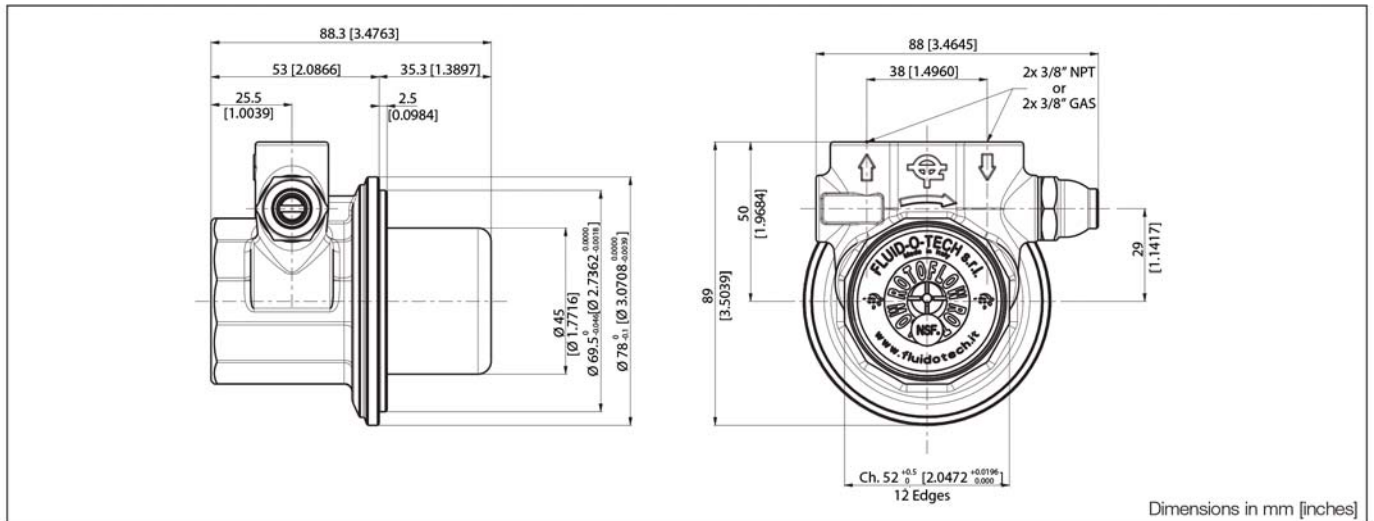

Table 1

Motor Adapter		
Position	Description	Part Number
1	TH Series Pump	Table 2
2	High Torque Mounting Assembly (M56-B16)	TMBS56C
	High Torque Mounting Assembly (M63-B14)	TMBS63C
	High Torque Mounting Assembly (NEMA 56C)	TMBS5BC

ABOUT RELIEF VALVES

Relief valves are offered on select models of rotary vane pumps throughout the product line. Two types of relief valves are offered:

- 1) Standard Relief valve: A spring loaded bypass check valve diverts flow from the pump outlet to the pump inlet when outlet pressure exceeds setpoint (set with spring tensioning set screw).
- 2) Balanced relief valve: A pressure compensation plunger with dynamic seal and referenced (ported on one side) to atmosphere is added to the downstream side of the standard check-valve assembly. This insures that cracking pressure of the relief valve remains unchanged regardless of changes in inlet pressure (that might be a condition in a pressurized system).

The cracking pressure can be field set by adjusting the spring tension with the adjusting screw. If the cracking pressure is not customer specified it is factory preset at approximately 190 PSI for TM 300-400 series.

It is not recommended to use the relief/bypass valve for flow control. This will result in premature wear of the valve assembly and require frequent maintenance.

PUMP MODEL SELECTION/FLOW CURVES

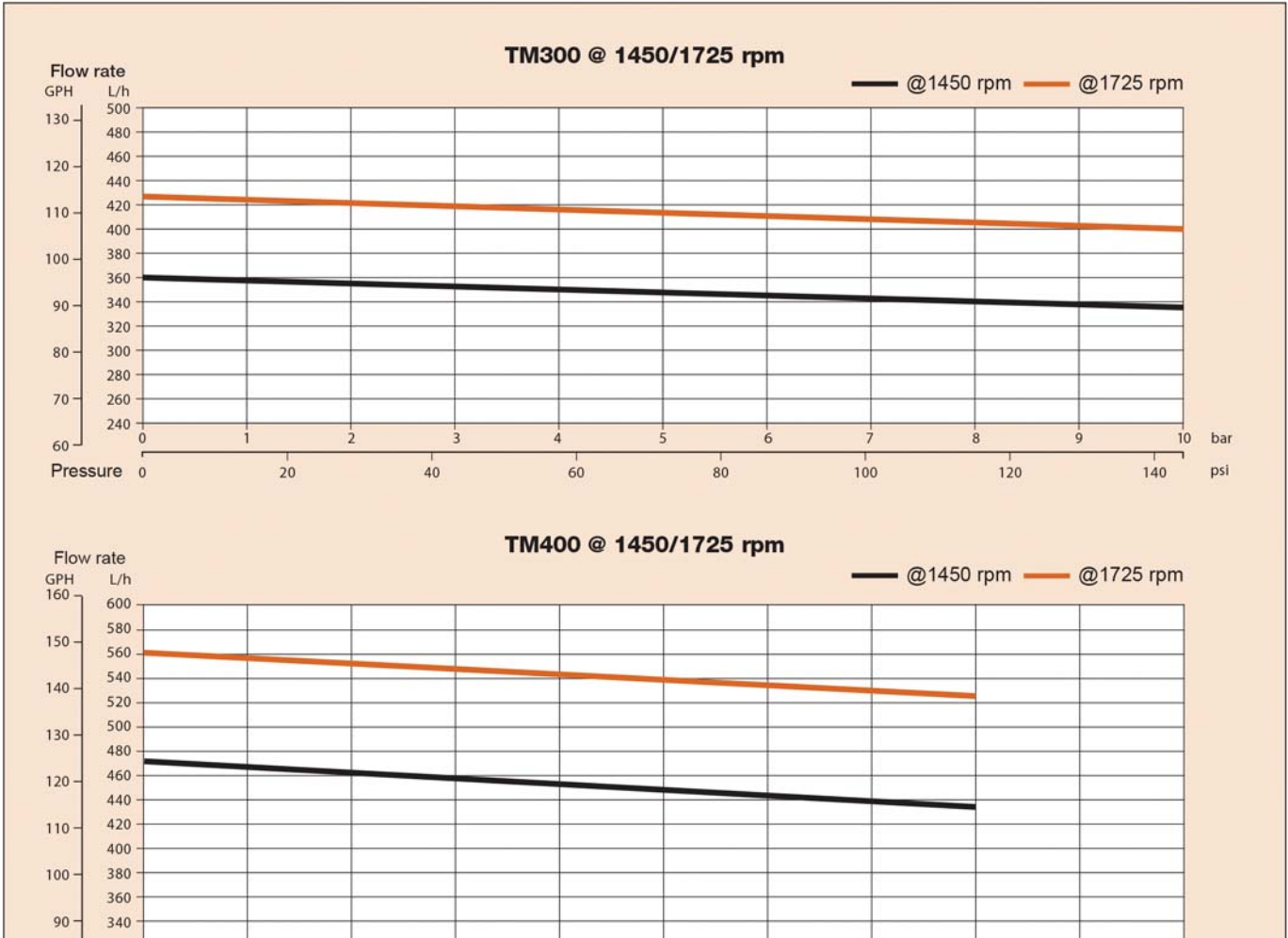

Table 2

Model	By-Pass
TMSS300	No
TMSS400	
TMSS301	Standard
TMSS401	
TMSS304	Balanced
TMSS404	