

VERDERFLEX®



Peristaltic Industrial Tube Pump

Operating Manual

Rapide

Version 1.0v-05/2013
Print No. 01

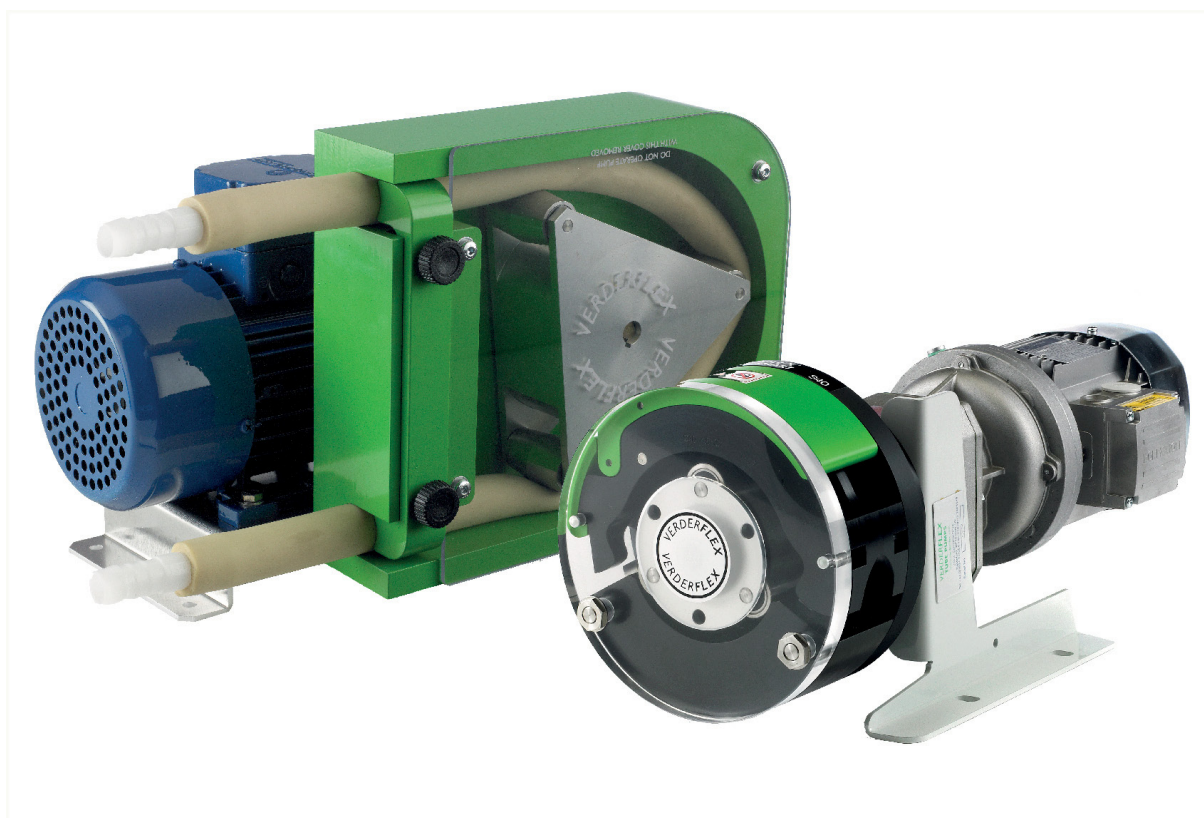

CE

VERDER 

Version 1.0v-05/2013
Print-No. 01

Rapide



The information in this document is essential for the safe operation and servicing of Verderflex® Rapide family of pumps. This document must be read and understood thoroughly prior to installation of unit, electrical connection and commissioning.

Table of contents

- 1. About this document**
 - 1.1 Target groups
 - 1.2 Warnings and symbols
- 2. Safety**
 - 2.1 Intended use
 - 2.2 General safety instructions
 - 2.2.1 Product safety
 - 2.2.2 Obligation of the operating company
 - 2.2.3 Obligation of personnel
 - 2.3 Specific hazards
 - 2.3.1 Hazardous pumped liquids
 - 2.3.2 Sharp edges
- 3. Layout and function**
 - 3.1 Design details
 - 3.2 Labelling
 - 3.2.1 Name Plate
 - 3.3 Layout - Rapide
 - 3.4 Layout - Rapide S
- 4. Transport, storage and disposal**
 - 4.1 Transport
 - 4.1.1 Unpacking and inspection on delivery
 - 4.1.2 Lifting
 - 4.2 Treatment for storage
 - 4.3 Interim storage before installation
 - 4.4 Disposal
- 5. Installation and connection**
 - 5.1 Preparing for installation
 - 5.1.1 Checking the ambient conditions
 - 5.1.2 Preparing the installation site
 - 5.1.3 Preparing the foundation and surface
 - 5.2 Installing the Rapide
 - 5.2.1 Key features
 - 5.2.2 Description of the pump head
 - 5.2.3 Installing the tube
 - 5.2.4 Changing the rotor
 - 5.3 Installing the Rapide S
 - 5.3.1 Key features
 - 5.3.2 Installing the tube
 - 5.2.3 Exploded view of Rapide S Head
 - 5.3.4 Description of the pump head
 - 5.3.5 Optional Tube Saddle Status Detection SSD
 - 5.3.6 Adjusting the tube clamp
 - 5.3.7 Installing a multi-channel pump head
 - 5.4 Electrical connection
 - 5.4.1 Installing motor and gearbox (where not supplied)
 - 5.4.2 Installing motor gearbox on bare-shaft pump
 - 5.4.3 Connecting to power supply
- 6. Operation**
 - 6.1 Starting the pump
 - 6.1.1 Switching on
 - 6.1.2 Switching off
 - 6.2 Operation
 - 6.2.1 Switching on
 - 6.2.2 Switching off (Refer to → 6.1.2)
 - 6.3 Operating the stand-by pump
- 7. Maintenance**
 - 7.1 Inspections
 - 7.2 Maintenance
 - 7.2.1 Cleaning the pump
 - 7.2.2 Maintenance schedule
 - 7.3 Repairs
 - 7.3.1 Preparations for dismounting
 - 7.3.2 Returning the pump to the manufacturer
 - 7.3.3 Rebuild / Repair
 - 7.4 Ordering spare parts
- 8. Storing pumps and tubes**
 - 8.1.1 Pre-Storage Actions
 - 8.1.2 Storage Conditions
- 9. Troubleshooting**
 - 9.1 Pump malfunctions
- 10. Appendix**
 - 10.1 Technical Specifications
 - 10.1.1 Pump Specifications - Rapide
 - 10.1.2 Pump Specification - Rapide S
 - 10.1.3 Tube Variants
 - 10.1.4 Ambient conditions
 - 10.2 List of Figures and Tables
 - 10.2.1 List of figures
 - 10.2.2 List of tables
 - 10.3 Declaration of conformity according to EC Machine Directive

1. About this document





The Verderflex Rapide peristaltic pump has been developed according to the latest technology and subject to continuous quality control. These operating instructions are intended to facilitate familiarization with the pump and its designated use. The relevant information will act as a guideline for you in operating the pump; alternative courses of action are also described should you be unable, for any reason, to follow those procedures initially given. You are advised to follow these guidelines to achieve maximum efficiency. These operating instructions do not take into account local regulations; the operator must ensure that such regulations are strictly observed by all, including the personnel called in for installation.

1.1 Target groups



Target group	Duty
Operating company	<ul style="list-style-type: none"> ▶ Keep this manual available at the operation site of the equipment, also available for later reference. ▶ Ensure that personnel read and follow the instructions in this manual and the other applicable documents, especially all safety instructions and warnings. ▶ Observe any additional rules and regulations referring to the system.
Qualified personnel, fitter	<ul style="list-style-type: none"> ▶ Read, observe and follow this manual and the other applicable documents, especially all safety instructions and warnings.

Tab. 1 Target groups and their duties

1.2 Warnings and symbols

Warning	Risk level	Consequences of disregard
	Immediate acute risk	Death, serious bodily harm
	Potential acute risk	Death, serious bodily harm
	Potential hazardous situation	Minor bodily harm
	Potential hazardous situation	Material damage

Tab. 2 Warnings and consequences of disregarding them

Symbol	Meaning
	<p>Safety warning sign in accordance with DIN 4844 - W9</p> <ul style="list-style-type: none"> ▶ Take note of all information highlighted by the safety warning sign and follow the instructions to avoid injury or death.
▶	Instruction
1. , 2. , ...	Multiple-step instructions
✓	Precondition
→	Cross-reference
	Information, recommendation

Tab. 3 Symbols and their meaning

2. Safety

i The manufacturer does not accept any liability for damage resulting from disregard of this documentation.

2.1 Intended use

- Only use the pump to handle compatible fluids as recommended by the manufacturer (→ 10.1 Technical specifications).
- Adhere to the operating limits.
- Consult the manufacturer regarding any other use of the pump.

Prevention of obvious misuse (examples)

- Note the operating limits of the pump with regard to temperature, pressure, flow rate and motor speed (→ 10.1 Technical specifications).
- **DO NOT** operate the pump while the inlet/outlet is closed.
- Only install the pump as recommended in this manual. For example, the following are not allowed:
 - Installing the pump without proper support.
 - Installation in the immediate vicinity of extreme hot or cold sources.
 - Explosive atmosphere

2.2 General safety instructions

i Observe the following regulations before carrying out any work.

2.2.1 Product safety

These operating instructions contain fundamental information which must be complied with during installation, operation and maintenance. Therefore this operating manual must be read and understood both by the installing personnel and the responsible trained personnel / operators prior to installation and commissioning, and it must always be kept easily accessible within the operating premises of the machine.

Not only must the general safety instructions laid down in this chapter on "Safety" be complied with, but also the safety instructions outlined under specific headings.

- Operate the pump only if the pumping unit and all associated systems are in good functional condition.
- Only use the pumping system as intended, fully aware of safety and risk factors involved, and in adherence to the instructions in this manual.

- Keep this manual and all other applicable documents complete, legible and accessible to personnel at all times.
- Refrain from any procedure or action that would pose a risk to personnel or third parties.
- In the event of any safety-relevant faults, shut down the pump immediately and have the malfunction corrected by qualified personnel.
- The installation of the pump, associated pipe work and electrical fittings must comply with the requirements of installation given in this manual and any local national or regional health and safety regulations

2.2.2 Obligation of the operating company

Safety-conscious operation

- Ensure that the following safety aspects are observed and monitored:
 - Adherence to intended use
 - Statutory or other safety and accident-prevention regulations
 - Safety regulations governing the handling of hazardous substances if applicable
 - Applicable standards and guidelines in the country where the pump is operated
- Make personal protective equipment available pertinent to operation of the pump; as required.

Qualified personnel

- Ensure that all personnel tasked with work on the pump have read and understood this manual and all other applicable documents, including the safety, maintenance and repair information, prior to use or installation of the pump.
- Organize responsibilities, areas of competence and the supervision of personnel.
- Have all work carried out by specialist technicians only.
- Ensure that trainee personnel are under the supervision of specialist technicians, at all times, when working on the pumping system.

Safety equipment

- Provide the following safety equipment and verify its functionality:
 - For hot, cold and moving parts: safety guarding should be provided by the operating company.
 - For potential build up of electrostatic charge: ensure appropriate grounding if and when required.

Warranty

i The warranty is voided if the customer fails to follow any and all instructions, warnings and cautions in this document. Verder has made every effort to illustrate and describe the product(s) in this document. Such illustrations and descriptions are, however, for the sole purpose of identification and do not express or imply a warranty that the products are merchantable or fit for a particular purpose, or that the products will necessarily conform to the illustration or descriptions.

Obtain the manufacturer's approval prior to carrying out any modifications, repairs or alterations during the warranty period. Only use genuine parts or parts that have been approved by the manufacturer.

For further details regarding warranty, please refer terms and conditions.

2.2.3 Obligation of personnel

i It is imperative that the instructions contained in this manual are complied with by the operating personnel at all times.

- Pump and associated components:
 - DO NOT lean or step on them or use as climbing aid
 - DO NOT use them to support boards, ramps or beams
 - DO NOT use them as a fixing point for winches or supports
 - DO NOT de-ice using gas burners or similar tools
- DO NOT remove the safety guarding for hot, cold or moving parts during operation.
- DO NOT install in hazardous areas.
- Reinstall the safety equipment on the pump as required by regulations after any repair / maintenance work on the pump.

2.3 Specific hazards

2.3.1 Hazardous pumped liquids

- Follow the statutory safety regulations when handling hazardous pumped liquids (e.g. hot, flammable, poisonous or potentially harmful).
- Use appropriate personal protective equipment when carrying out any work on the pump.

2.3.2 Sharp edges

- Use protective gloves when carrying out any work on the pump

3. Layout and function

i Peristaltic industrial tube pump, Verderflex Rapide, is simple by design in its construction and operation. The medium to be pumped does not come into contact with any moving parts and is totally contained within a tube. A rotor passes along the length of the tube, compressing it. This motion forces the contents of the tube directly in front of the rotor to move forward along the length of the tube in a 'positive displacement', peristaltic movement. In the wake of the rotor's compressing action, the natural elasticity of the tube material forces the tube to open and regain its round profile, creating suction pressure, which recharges the pump.

3.1 Design details

i The Verderflex Rapide range of tube pumps provide a balanced selection of simple to operate peristaltic pumps. The family offers the customer pump choices that are compact, can have multiple heads, are simple by design, and the Smart series provide rapid tube changeovers.

3.2 Labelling

3.2.1 Name Plate

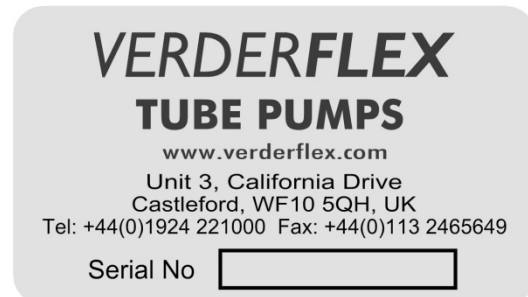

Figure 1 Name plate

Note: When requesting spares, the model and serial number should always be quoted.

3.3 Layout – Rapide

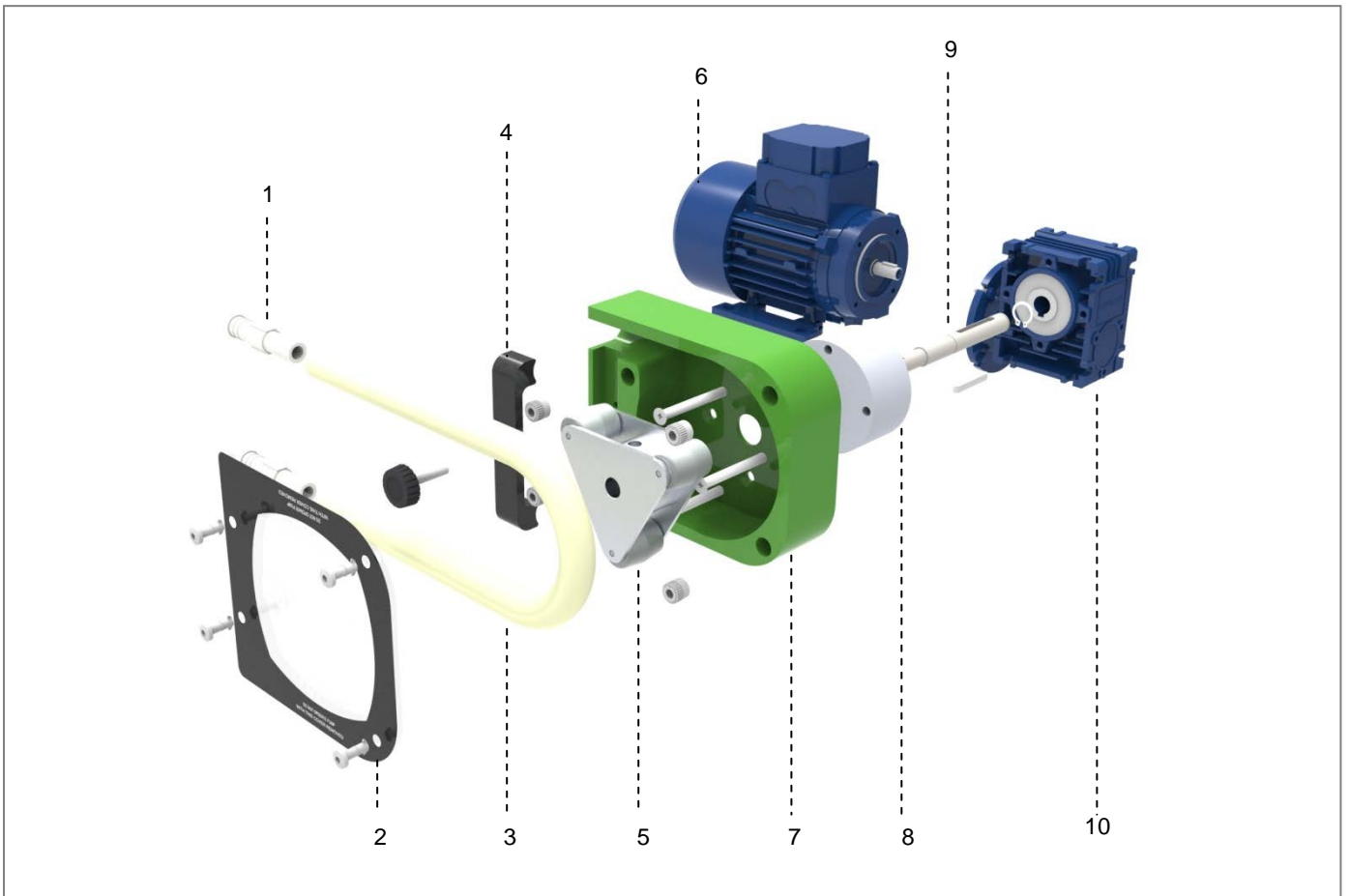

Figure 2 Layout

- | | | | | | |
|---|---------------------|---|----------------|----|--------------|
| 1 | Connectors | 5 | Rotor assembly | 9 | Drive shaft |
| 2 | Front cover | 6 | Motor | 10 | Worm gearbox |
| 3 | Tube element | 7 | Pump body | | |
| 4 | Tube clamp assembly | 8 | Adaptor sleeve | | |

3.4 Layout – Rapide ‘S’

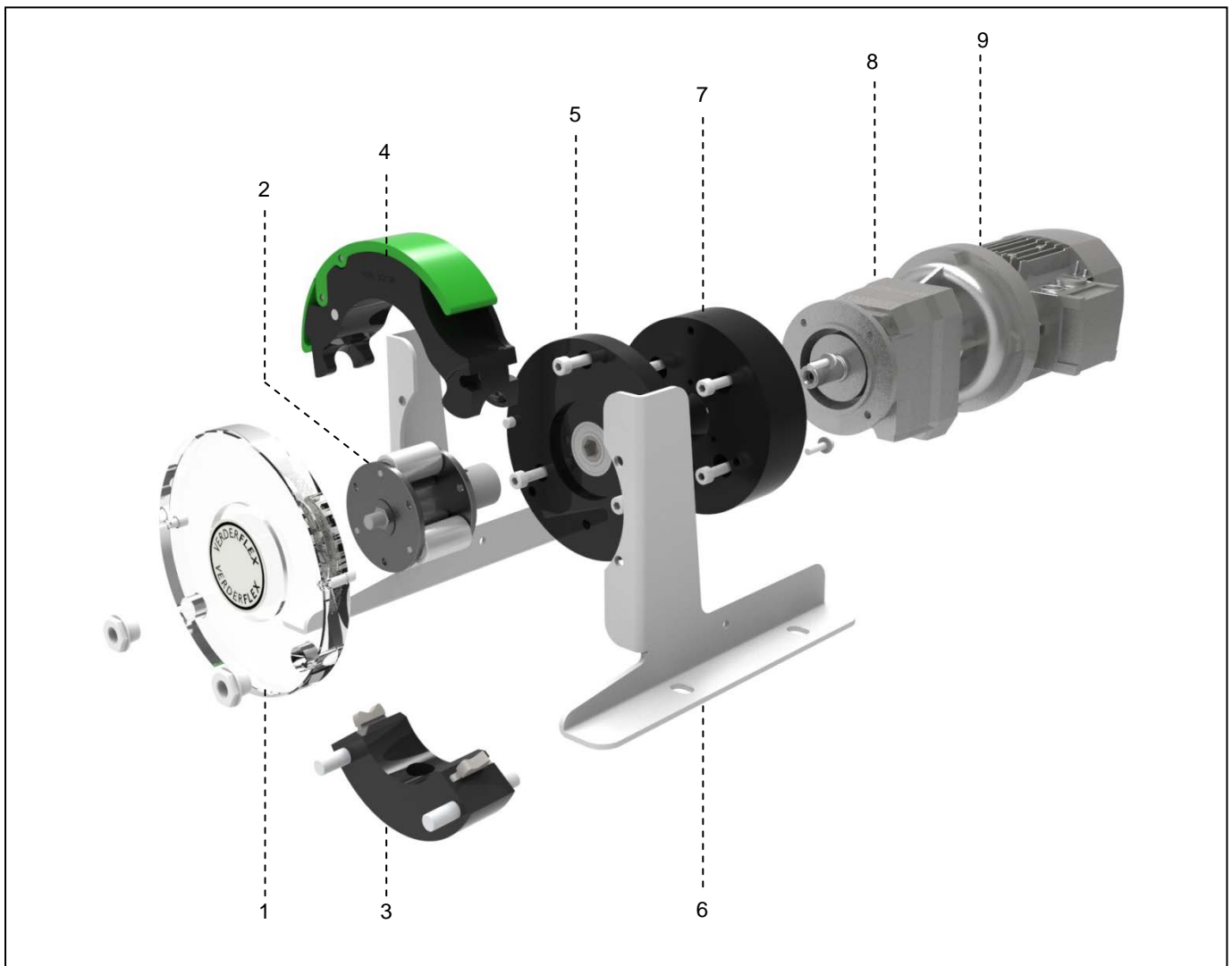



Figure 3 Layout

- | | | | | | |
|---|-----------------------------------|---|------------|---|-----------------|
| 1 | Front cover assembly with bearing | 4 | Saddle | 7 | Mounting flange |
| 2 | Roller and rotor assembly | 5 | Back plate | 8 | Gearbox |
| 3 | Clamping assembly | 6 | Frames | 9 | Motor |

4. Transport, storage and disposal

4.1 Transport

 Always transport the unit in an upright position and ensure that the unit is securely attached to the pallet.

4.1.1 Unpacking and inspection on delivery

1. Unpack the pump/pump unit upon delivery and inspect it for transport damage.
2. Report any transport damage to the manufacturer/distributor immediately.
3. Retain the pallet if any further transport is required.
4. Dispose all packaging material according to local regulations.

4.1.2 Lifting



Death or crushing of limbs can be caused by falling loads!

1. Use lifting gear appropriate for the total weight to be transported.
 2. DO NOT stand under suspended loads.
-

4.2 Treatment for storage

 Unpainted steel surfaces should be coated with rust inhibitor and the unit should be stored in a dry, dust free environment not exceeding 60°C

4.3 Interim storage before installation

 Make sure the storage room meets the following conditions:

- Dry, humidity not to exceed 80%
- Out of direct sunlight
- Frost-free; temperature range 0 to 40°C
- Vibration-free; minimize
- Dust-free; minimize

4.4 Disposal

 With prolonged use, pump parts can get contaminated by poisonous or radioactive pumped liquids to such an extent that cleaning may be insufficient.

WARNING

Risk of poisoning and environmental damage by the pumped liquid or oil!

- ▶ Use suitable personal protective equipment when carrying out any work on the pump.
- ▶ Prior to disposal of the pump:
 - Collect and dispose of any leaking pumped liquid or oil in accordance with local regulations.
 - Neutralize residues of pumped liquid in the pump.
- ▶ Dispose of the pump unit and associated parts in accordance with statutory regulations.

5. Installation and connection

NOTE

Material damage due to unauthorised modification on pump unit!

- ▶ DO NOT make any structural modifications to the pump unit or pump casing
- ▶ DO NOT carry out any welding work on the pump unit or pump casing

NOTE

Material damage caused by ingress!

- DO NOT remove any protective covers until immediately before installing the pump

5.1 Preparing for installation

5.1.1 Checking the ambient conditions

1. Make sure that the operating conditions are complied with (→ 10.1 Technical specifications)
2. Make sure the required ambient conditions are fulfilled (→ 10.1.4 Ambient conditions)

5.1.2 Preparing the installation site

- ▶ Ensure the installation site meets the following conditions:
 - Pump is freely accessible from all sides
 - Sufficient space is available for the installation/removal of the pipes and for maintenance and repair work, especially for the removal and installation of the tube.

5.1.3 Preparing the foundation and surface

- ▶ Make sure the foundation and surface meet the following conditions:
 - Level
 - Clean (no oil, dust or other impurities)
 - Capable of bearing the weight of the pump unit and all operating forces
 - Ensure the pump is stable and cannot tip over

5.2 Installing the Rapide

5.2.1 Key features

 Robust design with thick wall tube for suction and pressure handling.

1. Flow rates up to 840 l/hr (222 US GPH)
2. Pressures up to 2 Bar (29 PSI)
3. Typically used in:
 - Printing production
 - Dispensing
 - Industrial detergent applications

5.2.2 Description of the Pump Head

 The pump head comprises three main parts:

1. The rotor with rollers which are responsible for the peristaltic action of the pump
2. The transparent front cover, which allows the operator to check the pump operation and the direction of rotation.
3. The tube clamps, which can be adjusted for any permitted tube size. The purpose of the clamps is to stop the tube from 'walking' to the discharge side.

5.2.3 Installing the tube

1. Remove the clamp, but leave the front cover in place
2. Run the pump at low speed and carefully feed tube through the inlet
3. When tube reach outlet, use blunt end rod to guide the tube out.
4. Fit tube clamp loosely, and position tube with marked lines adjacent to edge of pump housing and tube clamp.
5. Tighten the tube clamp securely

5.2.4 Changing rotor

1. Align grub screw hole with flat on shaft
2. Align peak of roller with peak of tube track or set rotor distance back from front of pump housing as indicated (Refer Figure 4.2)
3. Fasten grub screw securely

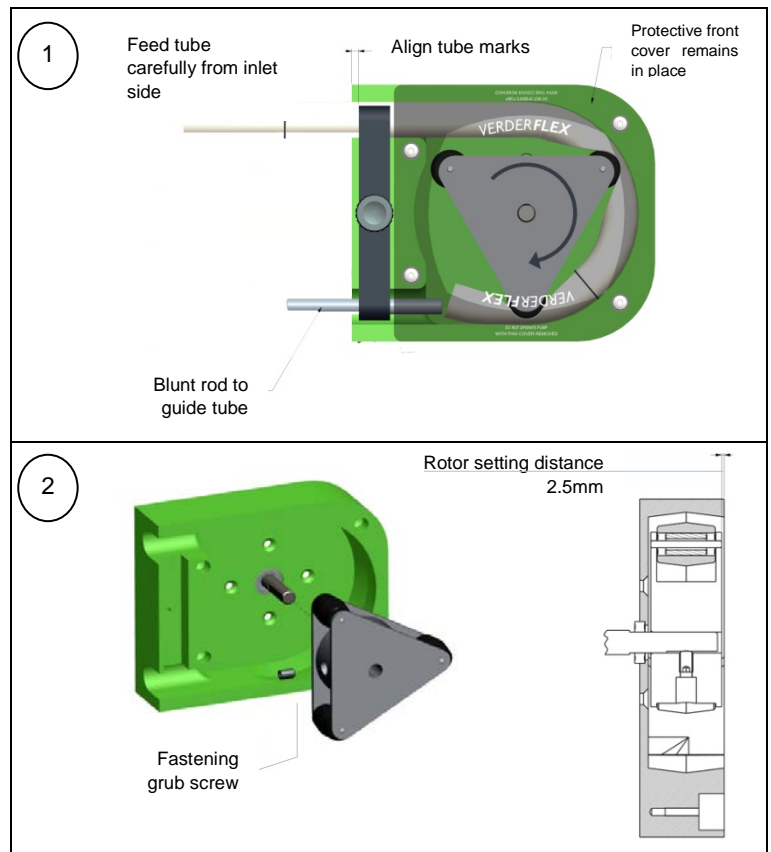



Figure 4 Installing tube on a Rapide

5.3 Installing the Rapide 'S'

5.3.1 Key features

 The Rapide 'S' includes a quick tube change, ergonomic design for ease of use.

1. Flow rates up to 1,020 l/hr (269 US GPH)
2. Pressures up to 2 Bar (29 PSI)
3. Multi channel options
4. Typically used in:
 - Chemical dosing
 - Industrial fluid transfer
 - Heavy duty environments

5.3.2 Installing the tube

1. Insert tube on top of the rollers
2. Fit the saddle to one set of dowels
3. Open up the ski boot handle and fit the catch over the saddle.
4. Push the handle down to lock the saddle into place over the other set of dowels.

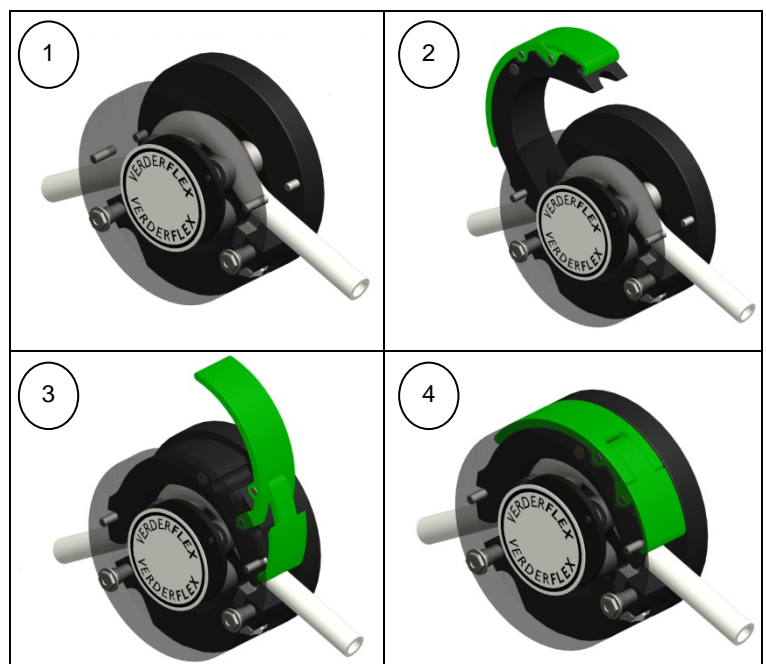

Figure 5 Installing tube on a Rapide S

5.3.3 Exploded view of the Rapide 'S' head

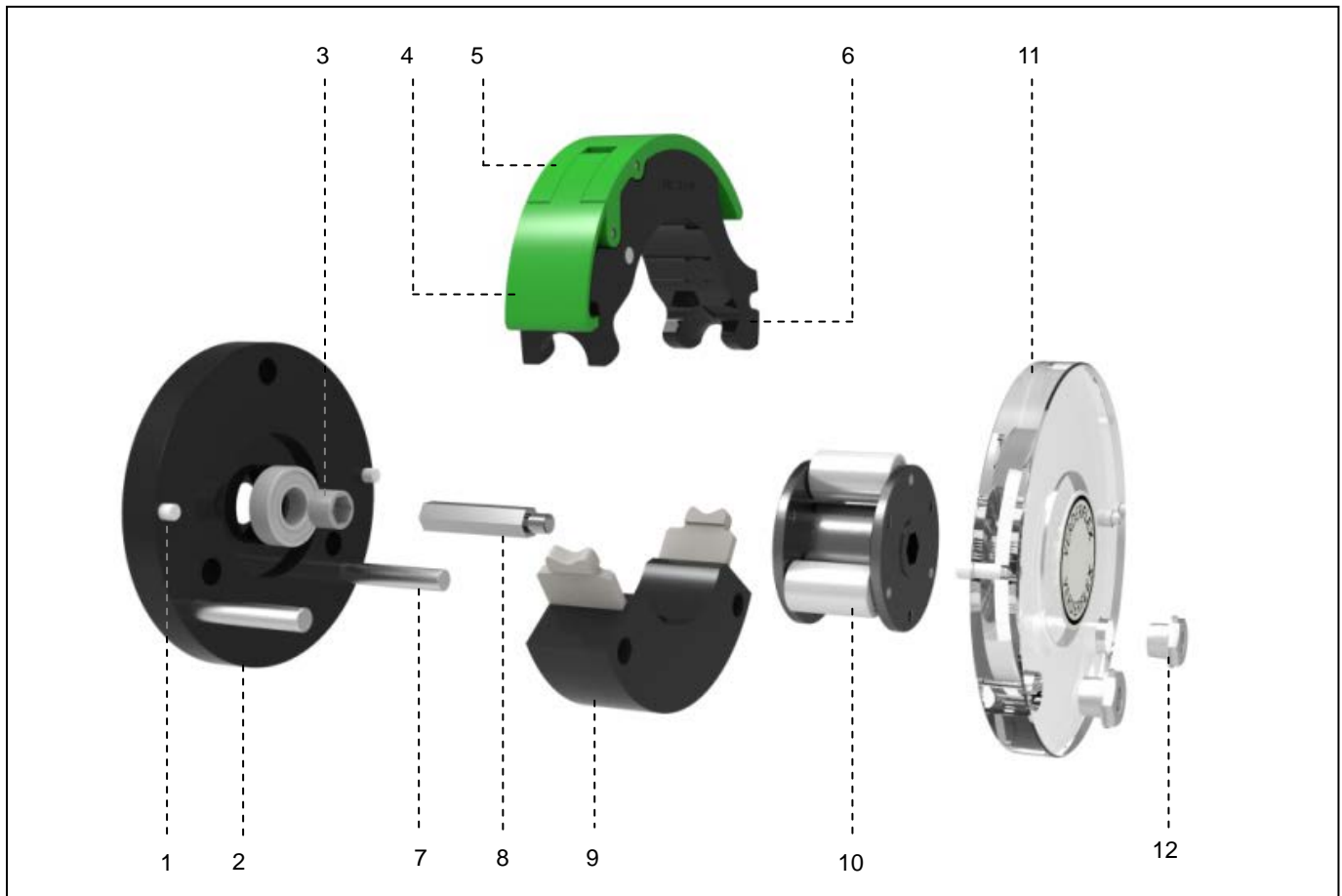



Figure 6 Exploded view of the Rapide S head

- | | | |
|-----------------------|-------------------|-----------------|
| 1 Dowels | 5 Ski boot handle | 9 Clamp base |
| 2 Back plate | 6 Saddle | 10 Rotor |
| 3 Drive coupling bush | 7 Tie bar | 11 Front Cover |
| 4 Ski boot catch | 8 Drive shaft | 12 Locking nuts |

5.3.4 Description of the Pump Head

 The Rapide 'S' pump head comprises four main parts:

1. The rotor with rollers which are responsible for the peristaltic action of the pump
2. The transparent front cover, which allows the operator to check the pump operation and the direction of rotation.
3. The lower section, which houses the U-shaped tube clamps. The tube clamps are adjusted, for any permitted tube size, by means of a screw driver slot or the thumb-screws, which are located in the underside/side of the clamp base. The purpose of the clamps is to stop the tube from 'walking' to the discharge side. On the pressure side, the clamps are designed to self-centre the tube.
4. The tube saddle counteracts the compressive action of the rotor. The saddle can be removed by unlocking the 'ski-boot' style lever.

5.3.5 Optional Tube Saddle Status Detection SSD

 The tube saddle status detection interlocks the tube saddle and the pump. The tube saddle status detection comprises two main components:

1. A reed switch embedded in the back plate of the pump head
2. A set of two magnets fitted to the tube saddle, one at either side. This means that it does not matter, which way round the saddle is fitted to the pump head.

When connected, the tube saddle status detection can detect if the tube saddle is fitted properly and can either:

- Not allow the pump to be started or,
- Stop the pump immediately if the saddle is opened while the pump is running.

5.3.6 Adjusting the tube clamp

 To insert the tube clamps, unscrew thumb-screw fully into tube clamp and slide into clamp base, unscrew thumb-screw sufficiently to insert clamp block over thumb-screw flange and into clamp base.

Take care that the tube clamp is inserted the correct way round, i.e. centre line of tube recess is in the centre of the clamp base. If this is not done the tube clamp will hit the tube saddle.

Tube clamp tensioning screws

1. Use a flat bladed screw driver to rotate the recessed screws, this will tension or slacken off the tube clamps respectively. Alternately adjust the thumb screw to adjust the clamps.
2. Rotate until tube is adequately tightened and tube walk is eliminated.

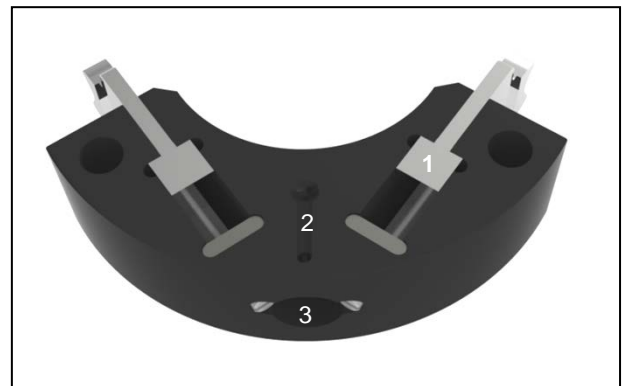

Figure 7 Tube clamp tensioning screw

1. Adjustable tube clamps.
2. Horizontal bore to thread cable from Reed switches through.
3. Recessed screws to adjust the tension of the tube clamps (Refer to Figure 6)



Figure 8 Tube clamp thumb screw (head variant)

5.3.7 Installing a multi-channel pump head

Installing a multi-channel pump head is very similar to the procedure of fixing a standard pump head. However, please note:

- Each channel is fitted with its own saddle status detector. The wires should be threaded through the horizontal bore of each lower pump head section, pointing towards the pump casing.
- Behind the back plate, which is bolted to the pump casing, connect the wires in series to the cable leading to the safety board.
- Finally stack up the individual components on the tie bars and drive shaft to assemble the multi pump head.

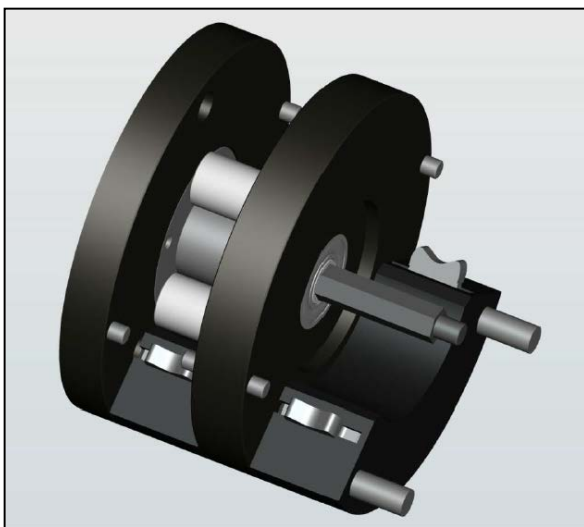

Figure 9 Installing a multi channel pump head.

5.4 Electrical connection

⚠ DANGER

Risk of electrocution!

- ▶ All electrical work must be carried out by qualified electricians.
- ▶ Make sure that the electrical information on the rating plate agrees with the power supply.
- ▶ Isolate the main supply before replacing the tube/cartridge
- ▶ Isolate the main supply before removing the enclosure cover.

5.4.1 Installing motor gearbox on bare-shaft pump

1. Lift motor and gearbox using suitable lifting gear.
2. Apply anti seize grease to the gearbox shaft.
3. Offer gearbox shaft up to the adaptor sleeve.
4. Align key to the key way.

5.4.2 Connecting to power supply

1. Connect motor to the rated power supply. Ensure the correct gland is used and that the earth connection is made and secured.
2. Run the pump slowly to ensure correct rotation.

6. Operation

6.1 Starting the pump

- ✓ Pump set up and connected properly
- ✓ Motor set up and connected properly
- ✓ All connections stress-free and sealed
- ✓ All safety equipment installed and tested for functionality

⚠ DANGER

Risk of injury and poisoning due to pumped liquid spraying out!

- ▶ Use personal protective equipment when carrying out any work on the pump.

⚠ WARNING

Risk of injury and poisoning due to hazardous pumped liquids!

- ▶ Safely collect any leaking pumped liquid and dispose of it in accordance with environmental rules and requirements.

⚠ DANGER

Equipment damage due to excess pressure!

- ▶ **DO NOT** operate the pump with the discharge-side fitting closed.
- ▶ Operate the pump only inside the tolerances specified by the manufacturer (→ 10.1 Technical specifications)

6.1.1 Switching on

1. Switch on the motor and make sure it is running smoothly.
2. Run the pump, flushing with water first (*cold commissioning*) to check for leaks.
3. Verify that neither the pump unit nor the tube connections are leaking.
4. Perform a second flush by running the pump, 10–20 revolutions with pumped liquid, to remove residue and water inside the pump.

6.1.2 Switching off

NOTE

Risk of dead heading and tube rupture due to closed suction or discharge!

- ▶ Keep the suction and discharge side fittings opened till the rotor has come to a complete stop.

6.2 Operation

6.2.1 Switching on

- ✓ Pump pre-commissioned (→6.1)
- ✓ Pump prepared and filled

DANGER

Risk of injury due to running pump!

- ▶ **DO NOT** touch the moving parts of a running pump.
- ▶ **DO NOT** carry out any repair/ maintenance work on the running pump.
- ▶ Allow the pump to cool down completely before starting any work on the unit.

1. Open the suction-side and the discharge-side fittings.
2. Switch on the motor and make sure it is running smoothly.

6.2.2 Switching off (Refer to → 6.1.2)

NOTE

Damage to tube due to sediments!

- ▶ If the pumped liquid crystallizes, polymerizes or solidifies
 - Flush the tube
 - Make sure that the flushing liquid is compatible with the pumped liquid.

6.3 Operating the stand-by pump

- ▶ Operate the stand-by pump at least once a week to avoid formation of permanent dents on the tube.

7. Maintenance

 Only trained service technicians should be employed for fitting and repair work. Present a pumped medium certificate (DIN safety data sheet or COSHH/ MSDS safety certificate) when requesting service.

DANGER

Risk of injury due to running pump or hot parts!

- ▶ **DO NOT** carry out any repair/maintenance work on a pump in operation.
- ▶ Allow the pump to cool down completely before starting any repair work.

7.1 Inspections

 The inspection intervals depend on the pump operating cycle.

1. Check at appropriate intervals:
 - Normal operating conditions unchanged
2. For trouble-free operation, always ensure the following:
 - No leaks
 - No unusual running noises or vibrations
 - Tube in position

7.2 Maintenance

 These pumps are generally maintenance free and any work should normally be limited to inspections; these may be more frequent in dust and/or hot condition.

DANGER

Risk of electrocution!

- ▶ Have all electrical work carried out only by qualified electricians.

7.2.1 Cleaning the pump

NOTE

High water pressure or spray water can damage motors!

- ▶ **DO NOT** clean motors with water or steam jet.
 1. Clean large-scale grime from the pump head.
 2. Rinse the tube carefully to remove chemicals

7.2.2 Maintenance schedule

Task	Frequency	Action
Check pump and gearbox for leaks and damage	<ul style="list-style-type: none"> - Before pump start up - Daily visual inspection - Scheduled intervals during operation 	<ul style="list-style-type: none"> ▶ Repair leaks and damage before operating the pump ▶ Replace components as necessary. ▶ Clean up any spillage.
Check geared motor unit lubrication level	<ul style="list-style-type: none"> - Before pump start up - Daily visual inspection - Scheduled intervals during operation 	<ul style="list-style-type: none"> ▶ → Gear motor instruction manual.
Check pump for unusual temperatures or noise in operation	<ul style="list-style-type: none"> - Daily visual inspection - Scheduled intervals during operation 	<ul style="list-style-type: none"> ▶ Check pump, gearbox and bearing housing for damage. ▶ Replace worn components.
Replace tube element	<ul style="list-style-type: none"> - After inspection, when required - When flow has dropped by 25% of nominal value - When the tube is ruptured/damaged 	<ul style="list-style-type: none"> ▶ Replace tube (→ 5.3.3 & 5.4.2 Tube change)
Check pump housing and rotor internally	<ul style="list-style-type: none"> - Annually - On replacing the tube 	<p>Worn and damaged surfaces give rise to premature tube failure</p> <ul style="list-style-type: none"> ▶ Replace worn components. ▶ Check bearing play and function.

Tab. 4 Maintenance schedule

7.3 Repairs



Risk of death due to electric shock!

- ▶ Have all electrical work carried out by qualified electrician only

7.3.1 Preparations for dismounting

- ✓ Pump completely emptied, flushed and decontaminated
- ✓ Electrical connections disconnected and motor locked out against being switched on again
- ✓ Pump cooled down
- ✓ Auxiliary systems shut down, depressurized and emptied



Risk of injury while removing the pump components!

- ▶ Use protective equipment when carrying out any work on the pump.
- ▶ Observe manufacturer's instructions (e.g. for Motor, coupling, gearbox...).

7.3.2 Returning the pump to the manufacturer

- ✓ Completely emptied and decontaminated.
- ✓ Pump cooled down
- ✓ Tube removed (→ 5.3.3 & 5.4.2 Removing the tube)

Obtain prior authorisation before repair or return of the pump.

- ▶ Enclose a completed document of compliance when returning pumps or components to the manufacturer

Repairs	Measure for return
...at the customer's premises	<ul style="list-style-type: none"> – Return the defective component to the manufacturer. – Decontaminate if necessary.
...at the manufacturer's premises	<ul style="list-style-type: none"> – Flush the pump and decontaminate it if it was used for hazardous pumped liquids.
...at the manufacturer's premises for warranty repairs	<ul style="list-style-type: none"> – Only in the event of hazardous pumped liquid, flush and decontaminate the pump

Tab. 5 Measures for return

7.3.3 Rebuild / Repair



Reinstall the components, in accordance with the marks applied.

NOTE

Material damage due to unsuitable components!

- ▶ Always replace lost or damaged bolts with bolts of the same strength and material.

1. Observe the following during the installation:
 - Replace worn parts with genuine spare parts.
2. Clean all parts.
3. Reassemble the pump (→ refer sectional drawing).
4. Install the pump in the system (→ 5 Installation and connection)

7.4 Ordering spare parts



For trouble-free replacement in the event of faults, we recommend keeping spare parts available on site.

- ▶ The following information is mandatory when ordering spare parts (→ Name plate):
 - Pump model
 - Year of manufacture
 - Part number / Description of part required
 - Serial number
 - Quantity

8. Storing pumps and tubes



Verderflex pumps are designed for continuous use, however, there may be instances when pumps are withdrawn from use and stored for extended periods. We recommend certain pre-storage actions and precautions be taken whilst pumps and their components are not in use.

Similarly, tubes and spares may be held in stock to service working pumps and their recommended storage conditions are advised.

8.1.1 Pre-Storage Actions

- The tube should be removed from the pump
- The pump casing should be washed out allowed to dry and any external build up of product removed.

8.1.2 Storage Conditions

- Pumps should be stored in a dry environment, out of direct sunlight. Depending on these conditions, it may be advisable to place a moisture-absorbing product, such as Silica gel, inside the pump's casing or to coat the pump's inner surfaces with moisture-repelling oil, such as WD40, whilst the pump is stored.
- Gearboxes may require intermittent attention as indicated by the gearbox manufacturer's recommendations.
- Tubes should be stored as supplied in their wrapper and should be stored away from direct sunlight and at room temperature.

9. Troubleshooting

9.1 Pump malfunctions

If malfunctions occur which are not specified in the following table or cannot be traced back to the specified causes, please consult the manufacturer.

Possible malfunctions are identified and respective cause and remedy are listed in the table.

PROBLEM	CAUSE	SOLUTION
Low Flow / low discharge pressure	Ratio of inner diameter / wall thickness too large for the application (tube too 'soft')	Use thicker wall thickness tube with the same inner diameter. This may require a different saddle or pump
		Run Pump slower with larger inner diameter tube
	Viscosity too high	Use a bigger tube or run the pump slower
	Suction lift too high, resulting in tube not fully returning to fully round	Use thicker wall thickness tube with the same inner diameter. This may require a different saddle or pump.
		Use a bigger pump running slower
	Wall thickness does not match the specifications of the saddle used.	Purchase appropriate saddle or change wall thickness
Discharge pressure too high	Poor flow is caused by excessive backflow, reduce discharge pressure	
Tube walks through pump head	Tube outer diameter too small for the pump head used	Adjust tube clamp tension
		Use tube with correct outer diameter.

Tab. 6 Pump troubleshooting list

10. Appendix

10.1 Technical Specifications

10.1.1 Pump Specifications – Rapide

Size	Value
Max. delivery pressure	2 bar
Temperature of pumped liquid	<i>Refer datasheet for tube variants</i>
Standard Speeds	68, 93, 137/140 and 196 rpm <i>depending on model</i>
Dimensions	<i>Refer datasheet for models</i>

Tab. 7 Pump Specifications– Rapide

10.1.2 Pump Specifications – Rapide ‘S’

Size	Value
Max. delivery pressure	2 bar
Temperature of pumped liquid	<i>Refer datasheet for tube variants</i>
Standard Speeds	60, 113, 151 & 220 rpm <i>depending on model</i>
Dimensions	→ Setup drawing

Tab. 8 Pump Specifications– Rapide ‘S’

10.1.3 Tube Variants

 For safety reasons we do not recommend pumping liquids greater than 85°C (185°F). The following criteria are important when selecting a tube:

- Chemical resistance
- Food grade quality
- Tube life
- Physical compatibility

Type	Feature
Verderprene	General purpose tubing
Silicone	High sterility tubing
Tygon	Chemical fluids tubing
Viton	Aggressive chemical tubing

Tab. 9 Verderflex Tube variants

10.1.4 Ambient conditions

 Operation under any other ambient condition would require approval from the manufacturer

Operating conditions

- Ambient temperature –5 °C to +45 °C
- Relative humidity
 - long—term ≤ 85 %
- Setup height above sea level ≤ 1000m / 3000 ft above sea level

Storage conditions

- Ambient temperature +10 °C to +50 °C
- Relative humidity
 - long—term ≤ 85 %

10.2 List of Figures and Tables

10.2.1 List of figures

Figure 1	Name plate.....	3.2.1
Figure 2	Layout – Rapide (Generic).....	3.3
Figure 3	Layout – Rapide ‘S’ (Generic).....	3.4
Figure 4	Installing tube on a Rapide.....	5.2.3
Figure 5	Installing tube on a Rapide ‘S’.....	5.3.2
Figure 6	Exploded view of the Rapide ‘S’ head.....	5.3.3
Figure 7	Tube clamp tensioning screw.....	5.3.6
Figure 8	Tube clamp thumb screw.....	5.3.6
Figure 9	Installing a multi channel pump head.....	5.3.7

10.2.2 List of tables

Table 1	Target groups.....	1.1
Table 2	Warnings and consequences of disregarding them.....	1.2
Table 3	Symbols and their meaning.....	1.2
Table 4	Maintenance schedule.....	7.2.2
Table 5	Measures for return.....	7.3.2
Table 6	Pump troubleshooting list.....	9.1
Table 7	Pumps specifications – Rapide.....	10.1.1
Table 8	Pumps specifications – Rapide ‘S’.....	10.1.2
Table 9	Tube variants.....	10.1.3
Table 10	Declaration of conformity according to EC Machine Directive.....	10.3

10.3 Declaration of conformity according to EC Machine Directive

<p>EC declaration of conformity according to machine directive, appendix II A</p> <p>We, VERDER Ltd., Unit 3 California Drive, Castleford hereby declare that the following machine adheres to the relevant EC directives detailed below</p> <p>Designation Verderflex Rapide Verderflex Rapide 'S'</p> <p>EC directives:</p> <ul style="list-style-type: none"> • Machine Directive (2006/42/EC) • Low-voltage directive (2006/95/EC) • EMC directive (2004/108/EC) <p>Applicable harmonized norms:</p> <ul style="list-style-type: none"> • EN ISO 12100: 2010 		
Responsible for the documentation	VERDER Ltd. Unit 3 California Drive Castleford WF10 5QH UK	
Date: 01/ 05/ 2013	Company stamp / signature:  David Sampson Head of Development	Company stamp / signature:  Andrew Metcalfe Head of Quality

Tab. 10 Declaration of conformity according to EC Machine Directive

