

INSTRUCTION MANUAL

DIRECT DRIVE ROTARY VANE PUMPS PO4000 SERIES

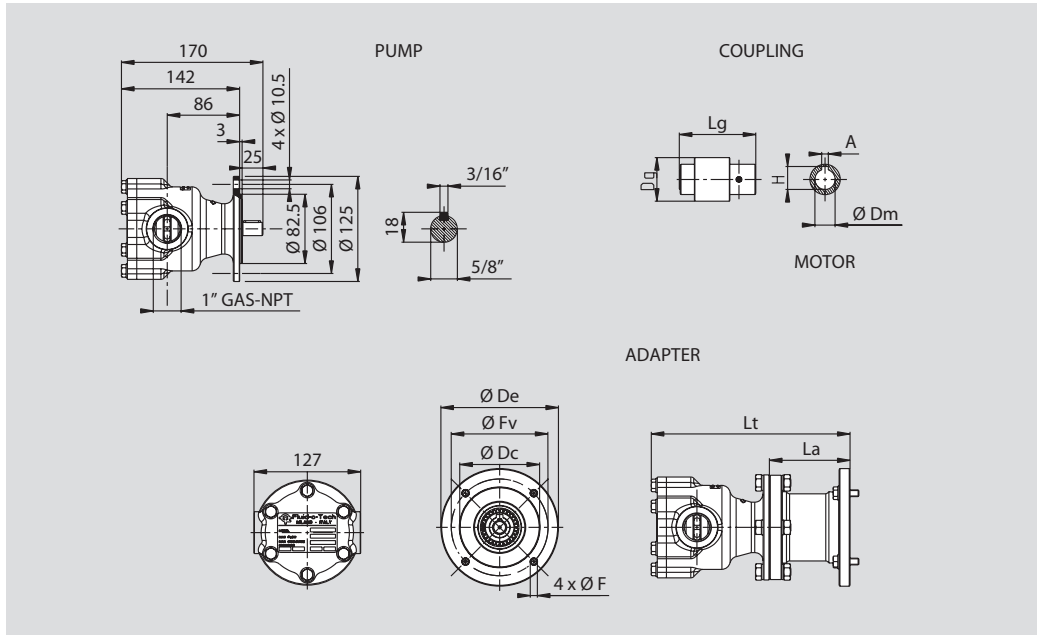

Find out more

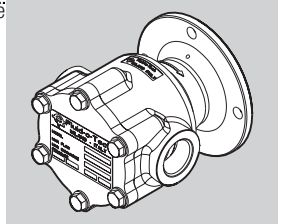

MOTOR	ADAPTER						COUPLING				
	Ø Dc	Ø Fv	Ø F	Ø De	La	Lt	Lg	Dg	Ø Dm	A	H
M80	80	100	7	120	86	188	81	52	19	6	21.5
M90	95	115	9	140	96	238	91		24		27
M100	110	130		160	100	242	95		68		28
Nema 56C	4.5"	5.875"	0.433"	6.5"	3.898"	4.449"	3.07"	2.047"	5/8"	0.19"	0.7165"
Nema 143TC - 145TC							3.583"				7/8"

All measures for M80/M90/M100 are in mm
 All measures for Nema 56C/Nema 143TC - 145TC are in inch

Distributor Contact:

Clark Solutions
 10 Brent Drive
 Hudson, MA 01749
 Tel: 978-568-3400
 Website: www.clarksol.com
 e-mail: sales@clarksol.com

INSTALLATION

The pump has to be installed exclusively by authorized staff. Handle with care.

It's recommended not pulling out the two protection sponge caps placed on the inlet and outlet ports of the pump before mounting the fittings and the pipes in order to avoid the incidental entrance of any solid estraneous object which might damage the internal components of the pump.

The PO4000 series rotary vane pumps look identical in their exterior aspect, although the flow rates are different. For this reason, when substituting just the pump, it is necessary to check the model of the new one. Changing the pump with a model of different capacity may damage the system, the motor and the pump itself.

If continuous operation is needed, the pump has to be mounted in an airy space in order to dissipate the heat produced from the motor. The pump must be mounted horizontally.

To avoid vibrations of mechanical parts and noise it is advisable to mount the motor with rubber shock-absorbing supports.

WIRING THE MOTOR TO THE POWER SUPPLY

- The power supply must be consistent with the electrical data stamped on the motor plate, with particular regard to voltage, frequency and current.
- The power supply should be switched off during installation.
- The motor rotation must be clockwise (looking at the motor in front). If operated counter clockwise, the pump won't work.
- In case the rotation is counterclockwise, proceed according to the scheme generally enclosed in the electrical wiring box.
- If the pump fails or some estraneous object enters it, the group may stop or work in critical conditions; for this reason the motor should have a thermal protection to avoid overheating or a current protection to avoid overloading.

MOUNTING THE PUMP ONTO THE MOTOR

The overall dimension drawing of the pump is shown on the last page of this leaflet. When mounting the pump onto the motor, it's advisable to pay the maximum attention in order to avoid shocks against the shaft, checking the correct alignment and verifying, after mounting, that the shaft turns free.

How to proceed:

- Make sure the motor is unplugged from the electric line
- Check that the key is tight on the motor shaft
- Mount the motor side of the coupling on the motor, without hammering it.
- Tighten the set screw (only for the couplings equipped with set screw).
- Insert the shock absorber in the coupling on the motor side.

- Secure the pump side of the coupling on the pump, without hammering it.
- Mount the adapter on the motor flange and tighten the screws.
- Mount the pump on the motor by inserting the coupling side of the pump shaft into the coupling side of the motor shaft.
- Turn the pump to the position desired and stop it by tightening the 4 bolts.

NOTE: The motor should be a 4 poles type with B3 B14 frame, with power between 1.5 and 2.2 Kw, in accordance to the capacity of the pump (325 to 700 gph) and to the operating pressure.

Take into account that the pump performs differently if operated at 50 Hz (1450 rpm) or 60 Hz (1725 rpm).

Do not run the pump with a 2 poles motor (2900 rpm at 50 Hz or 3500 rpm at 60 Hz). Running the pump at such speed, highly affects the life of the mechanical seal.

CONNECTING THE PUMP TO THE CIRCUIT

- A particular care is needed while mounting the fittings, to avoid liquid leaks.
- If using Teflon tape it's important that no particles of it fall into the pump.

Avoid using liquid sealer since it may glue the pump's components if it enters the pump.

It is advisable to use fittings made of stainless steel or plastic.

- The circuit should be carefully flushed before starting the pump.

OPERATING CONDITIONS

- Make sure that the pumped fluid is compatible with the materials of the pump. For particular applications, contact the nearest Fluid-o-Tech authorized distributor.
- Avoid as well to use liquids with temperature $\geq 70^\circ\text{C}$ (158 F).
- It's strongly recommended using pipes and connections of suitable size for the pump capacity, with internal diameter of at least 25 mm (1 inch), especially on the inlet side. This precaution avoids the possibility of cavitation and consequent damage of the pump.
- The maximum differential pressure should not exceed 18 bar (260 psi).
- The maximum system pressure should not exceed 20 bar (290 psi).

The graph here below reports the NPSH (Net Positive Suction Head) for the PO4000 series run at 1450 and 1725 rpm. Although this is a positive displacement pump,

it is strongly recommended not to operating it over the values specified by the curves in the graph. Priming and operating the pump above the curve will result in cavitation. This will bring noisy operation and premature failure.

Make sure that the NPSH value of the circuit is higher than the NPSH value of the pump.

The Rotoflow pump is designed to handle clean fluids only. Any particle bigger than $10\ \mu\text{m}$ wears the graphite components out in a short time; it is recommended for this reason mounting, before the pump, a filter sized to keep out particles bigger than $10\ \mu\text{m}$ and with a surface area big enough, in order not to cause hydraulic losses in the circuit. Check periodically the good conditions and the cleanliness of the filter. Certain descaler mixes used to clean hydraulic circuits are not compatible with the pump components and tend to glue the graphites.

For this reason it is always recommended verifying the compatibility of the material of the components with the liquid pumped.

A dirty filter or an insufficient supply of water could cause cavitation and wear of the internal components of the pump. Although the rotary vane pumps are self-priming, dry running may cause overheating and fast wear of the mechanical seal and of the internal components.

As a consequence of prolonged dry running, some leak may occur. If the intake is subject to low pressure conditions, it is necessary to fit a low pressure switch in order to turn the motor off when the pump is starved. In order to avoid cavitation, do not install the pump more than 1.5 m above the maximum liquid level of the tank.

Refer in any case to the NPSH curve shown on this leaflet. It is also necessary to protect the system from incidental overpressures with safety devices such as a pressure relief valve or a pressure switch connected to the motor.

Solenoid valves should not be installed in the circuit; however, if needed, a mechanical safety valve needs to be installed before the solenoid valve, in order to protect the pump from pressure peaks. Solenoid valves before the pump have to be avoided at all times.

STANDARD MAINTENANCE, SUBSTITUTION OF PARTS SUBJECT TO WEAR

- The maintenance, and the replacement of the parts subject to wear has to be done by an authorized technician.
- A few drops of water from the drain holes of the pump are normal during the first hours of operation. In case the leaking persists, please contact the nearest Fluid-o-Tech distributor.

Max pressure: 18 bar/ 260 psi - Max system pressure: 20 bar/290 psi

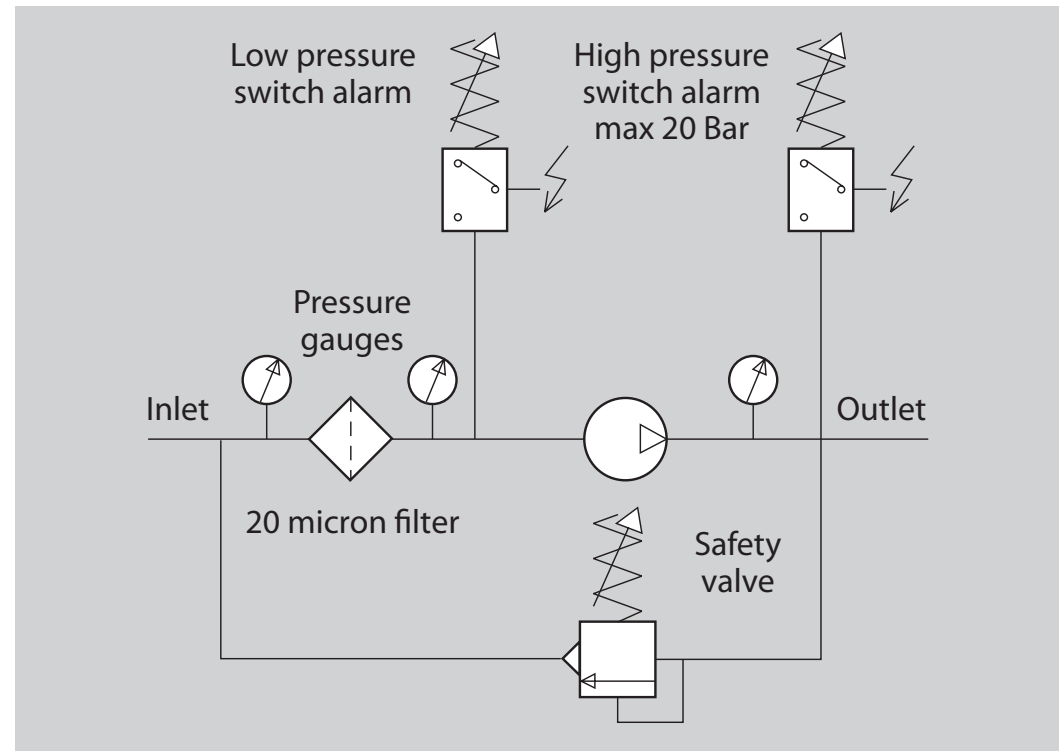

WARRANTY

Every new pump manufactured by Fluid-o-Tech is guaranteed to be free of defects in workmanship and material when leaving the factory for a period of 12 months from the production date stamped on the pump's housing, plus a period of 3 months to cover the warehouse and transit time, or for a period of maximum 15 months for the purchasing date to the for product use. In no event shall this period exceed 15 months from date of original invoice. Fluid-o-Tech will repair or replace at its judgement part or all of the product not conforming to this warranty. Fluid-o-Tech's responsibility under this warranty is limited to the repair or replacement of defective equipment returned to us on a D.D.P. basis, providing that our analysis discloses that such part or parts were defective at the time of sale.

The warranty is not recognized if:

- The directions on how to handle, install or operate the pump are disregarded.
- The pump has been disassembled or modified by

anyone other than a Fluid-o-Tech (or authorized by Fluid-o-Tech) engineer or repaired with non original components.

- The pump operated dry or in cavitation.
- Solid extraneous particles are found in the pump.
- Evident signs of over pressure are observed (over 17 bar/250 psi for the pumps with flow rate up to 1.000 l/h and 18 bar/260 psi for the pumps with flow rate between 1.000 l/h and 2.400 l/h).
- The pump has been utilized for an application for which it was not intended to be used where the operating conditions and/or the pumped liquid were incompatible with the pump itself and such application has not been specifically approved by Fluid-o-Tech.
- In case of pumps equipped with relief valve, the operating pressure results to be less than 1 bar below the relief valve setting.

The adjustment or replacement of defective parts made under this warranty will not extend the original warranty period.