

WARRANTY

Every new pump manufactured by Fluid-o-Tech is guaranteed to be free of defects in workmanship and material when leaving the factory for a period of 18 months from the production date stamped on the pump's housing, plus a period of 6 months to cover the warehouse and transit time, or for a period of maximum 24 months from the purchasing date to the product use. In no event shall this period exceed 24 months from date of original invoice.

Fluid-o-Tech will repair or replace at its judgement part or all of the product not conforming to this warranty.

Fluid-o-Tech's responsibility under this warranty is limited to the repair or replacement of defective equipment returned to us on a D.D.P. basis, providing that our analysis discloses that such part or parts were defective at the time of sale.

The warranty is not recognized if:

- The directions on how to handle, install or operate the unit are disregarded.

- The unit has been disassembled or modified by anyone other than a Fluid-o-Tech (or authorized by Fluid-o-Tech) engineer or repaired with non-original components.
- The unit operated dry or in cavitation (throttled/undersized inlet or filter).
- Solid extraneous particles are found in the pump.
- Evident signs of operating pressure higher than 16 bar (high pressure may compromise the integrity of the internal parts of the pump and cause leaking) are found.
- The unit has been utilized for an application for which it was not intended to be used where the operating conditions and/or the pumped fluids were incompatible with the pump itself and such application has not been specifically approved by Fluid-o-Tech.
- In case of pumps equipped with relief valve, the operating pressure have to be less than 3 bar below the relief valve pressure setting. In this case the internal parts get hot, scale develops and the hydraulic performances degrades.

Distributor Contact:

Clark Solutions
 10 Brent Drive
 Hudson, MA 01749
 Tel: 978-568-3400
 Website: www.clarksol.com
 e-mail: sales@clarksol.com

Fluid-o-Tech reserves the right to alter the specifications indicated in this catalogue at any time and without prior notice.

Fluid-o-Tech srl
 Via Leonardo da Vinci, 40
 20094 Corsico, Milano, Italy
 Tel. +39 02 9995 01
 Fax +39 02 9995 0999
 info@fluidotech.it

Fluid-o-Tech Int'l Inc.
 161 Atwater St.,
 Plantsville CT (USA) 06479
 Tel. +1 (860) 276 9270
 Fax +1 (860) 620 0193
 info@fluid-o-tech.com

Fluid-o-Tech Int'l Inc. Japan
 203, 2-17-19, Ebara, Shinagawa
 Tokyo 142-0063, Japan
 Tel. +81 (0) (3) 3783 9660
 Fax +81 (0) (3) 3783 9661
 k.kato@fluidotech.com

Fluid-o-Tech Asia (Beijing) Co., Ltd
 Jingwei Industrial Zone,
 Belfang Huairou, Beijing, 101400, PRC
 Tel. +86 (0) (10) 6168 4650
 Fax +86 (0) (10) 6168 4651
 info@fluidotech-asia.com



INSTRUCTION MANUAL

DRIVER TMFE2 FOR TMFR-TSFR PUMP AND MOTOR UNIT

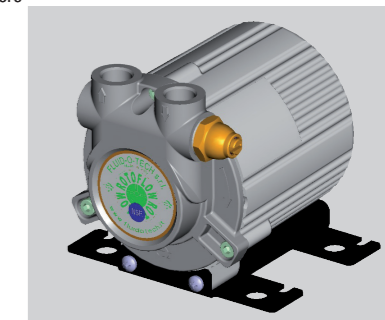

LEGEND



Indicates a warning of a dangerous voltage. Concerning a generic danger this symbol indicates a high or important operative notes. Voltage condition which may cause a serious accident or death.

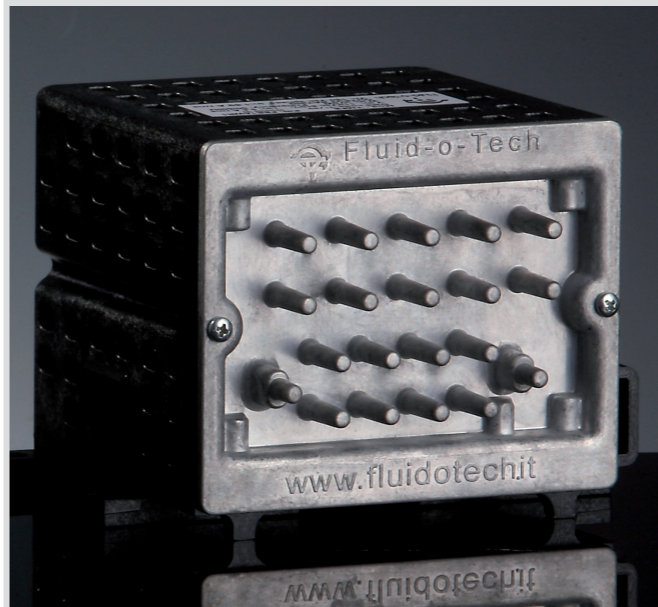

FOREWORD

REPAIRS NOTE

Repairs may be performed only by workshops authorized by Fluid-o-Tech who must use genuine spare parts.

Unauthorized repairs and the use of other spare parts can result in personal injuries and property damage as well as loss of UL approvals and safety functions, such as Safety Integrated.



Warning TMFR/TSFR units are used in high voltage installations and are operated at voltages that when touched can cause serious injuries or death!

PROPER USE

Note the following:



Warning This device may only be used as described in the catalog and in the technical description and only in connection with third-party devices and

components recommended or approved by Fluid-o-Tech. To ensure trouble-free and safe operation of the product, it must be transported, stored and installed as intended and maintained and operated with care.

SAFETY INFORMATION

This documentation contains information that must be observed to ensure your personal safety and to prevent material damage. The instructions for your personal safety are marked by a warning triangle. Instructions relating solely to material damage are not marked by a warning triangle. The warnings appear in decreasing order of risk as given below.



Danger Indicates that death or serious injury will result if proper precautions are not taken.

Warning Indicates that death or serious injury may result if proper precautions are not taken.

Caution With a safety alert signal indicates that minor personal injury can result if proper precautions are not taken.

Without a safety alert symbol, indicates that property damage can result if proper precautions are not taken.

Notice Indicates that an undesirable result or state may arise if the relevant note is not observed.



Warning: leakage current as a result of the high switching frequencies, capacitances (parasitic and integrated) with respect to ground may cause leakage currents. This is the reason that a permanent

PE connection is required. The presence of the filter implies an unavoidable increase of leakage current to the ground; it is therefore suggested the use of a proper differential switches with intervention for current ≥ 30 mA.



Warning: the TMFR/TSFR board control is not insulated from power network. The components of the inverter are under voltage when the unit is connected to main supply. Contact with this voltage can cause serious damage. The power supply of the inverter must be protected by a fuse or with an automatic cutout. Make sure that cables, especially ground wire, are fixed properly. Keep separate the power cables from the signal cables. Connect a spark quenching unit in parallel to relays coils, solenoid valves and remote control switches closely to the electronic, as in the following table:

| REMOTE CONTROL SWITCH OR SOLENOID VALVE | SPARK QUENCHING UNIT CHARACTERISTICS |
|---|--------------------------------------|
| 220Vac, 240Vac >30A | 0.5 μF + 100 Ω 0.5W 250V |
| 220Vac, 240Vac <30A | 0.1 μF + 100 Ω 0.5W 250V |
| 24Vcc | Diode |

Warning:

The failure protection circuit towards earth is designed ONLY to protect the inverter from failures earth, occurring on the motor cable or on the motor itself. The failure protection is NOT designed to protect people touching the motor or the power cables.

It is forbidden:

To connect PFC (Power factor correction) devices to the outlet terminals between the inverter and the motor.

To connect capacitors between the outlet terminals or the outlet terminals and the ground.

NOTE

• It is advisable to avoid the connection of the remote control switches to the terminals between inverter and motor unless they operate with stopped motor and inverter.

• When handling cables, please observe the following:

- are not damaged
- they may not be stressed,
- they may not come into contact with rotating components.

Notes concerning responsibility

The TMFR2-TSFR2 driver is a device designed to control the speed of the pump-motor unit and it must be used with this purpose. Under no circumstance the manufacturer will be held responsible for any damage caused by misuse, wrong installation or incompatible environmental conditions, nor for failures caused by operation beyond the nominal values. The manufacturer declines as well any responsibility arising from subsequent accidental damages. There are no internal parts of the machine where it is possible to intervene.

Tampering with the unit or using non-original spare parts avoid the warranty and may cause damages and serious injuries.

Warning



Start-up/commissioning is absolutely prohibited until it has been ensured that the machine in which the components described here are to be installed, fulfills the regulations/specifications of the Directive 2006/42/CE. If this is not observed, this can result in injury.

Warning



The information and instructions in all of the documentation supplied and any other instructions must always be observed to eliminate hazardous situations and damage.

- For special versions of the machines and equipment, the information in the associated catalogs and quotations applies.
- Further, all of the relevant national, local land plant/system-specific regulations and specifications must be taken into account.
- All work should be undertaken with the system in a no-voltage condition! If this is not observed, this can result in injury.

Warning



The capacitors mounted in the unit have dangerously high voltage. For this reason, once the power cord has been disconnected, it is necessary **to wait three (3) minutes minimum before any service on the device.**



ESDS information and instructions

Electrostatic Discharge Sensitive Devices Components, which can be destroyed by electrostatic discharge are individual components, integrated circuits, or boards, which when handled, tested, or transported, could be destroyed by electrostatic fields or electrostatic discharge. These components are referred to as ESDS (ElectroStatic Discharge Sensitive Devices).

Handling ESDS modules:

- When handling devices which can be damaged by electrostatic discharge, personnel, workstations and packaging must be well grounded!
- Generally, electronic modules may not be touched unless work has to be carried out on them.
- Personnel may only touch components if they are continuously grounded through ESDS wristlets, they wear ESDS shoes, ESDS shoe grounding strips in conjunction with an ESDS floor surface. Boards/modules must only be placed on conductive surfaces (table with ESDS surface, conductive ESDS foam, ESDS packaging, ESDS transport container).
- Modules may not be brought close to data terminals, monitors or television sets (minimum clearance to the screen > 10 cm).
- Do not bring ESDS-sensitive modules into contact with chargeable and highly-insulating materials, such as plastic sheets, insulating table tops or clothing made of synthetic materials.
- Measuring work may only be carried out on the components if the measuring unit is grounded (e.g. via a protective conductor) or when floating measuring equipment is used, the probe is briefly discharged before making measurements (e.g. a bare-metal control housing is touched).

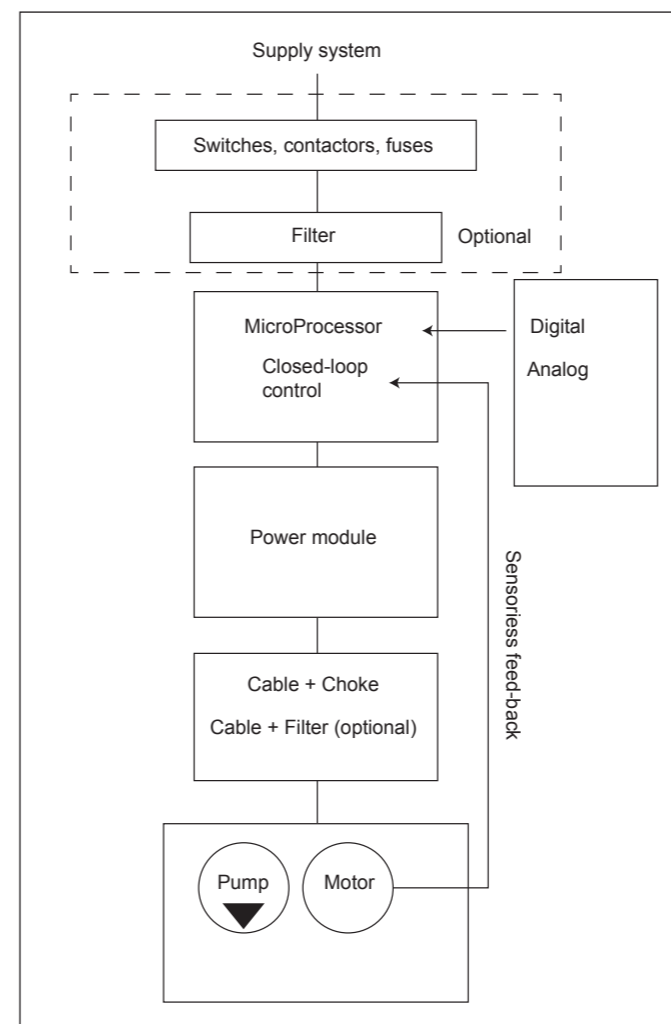

SYSTEM CONFIGURATION

Ambient conditions

Note

- The components are insulated in compliance with EN 60335-1.
 - Overvoltage category II for industrial line supplies
 - Degree of pollution II, especially no conductive pollution, moisture
 - Condensation is not permissible
 - Installation altitude up to max. 2000 m above sea level
- Conform to category 3M4 according to CEI EN 60721-3-3

Warning

Any conductive dirt/pollution can result in the safe electrical separation being lost and can therefore result in hazards to personnel (electric shock).

Note Appropriate measures (filter, waiting cycles, etc.) must be adopted to prevent contamination of the cooling system, in order to maintain proper cooling efficiency.

GENERAL INFORMATION

| MODEL | Input [Vac] | Inverter [KWA] | Nominal input current | Out motor current [A] | Motor power [A] | Weight [KWA] | STANDARD [Kg] |
|-----------|---------------------------------|----------------|-----------------------|-----------------------|-----------------|--------------|--|
| FEXXEXXX | 230V (±10%) 50/60 Hz sing/ph | 0.25 | 1.8 | | | 0.9 | Safety CEI EN 60335-1 |
| TMFR/TSFR | 110V per ph 30/120 Hz | | | 1.26 | 0.25 | 3 | EMC: CEI EN 61000-6-1 CEI EN 61000-6-3 CEI EN 61000-6-4 |
| FEXDXXX | 230V (±10%) 50/60 Hz sing/ph | 0.25 | 1.8 | | | 0.9 | UL 60730-1a |
| TMFR/TSFR | 110V per ph 30/120 Hz | | | 1.26 | 0.25 | 3 | UL 778 CSA C22.2 n. 108 |
| FEXXAXXX | 115V (±10%) 50/60 Hz sing/ph | 0.25 | 3,6 | | | 0.9 | UL 60730-1a |
| TMFR/TSFR | 110V per ph 30/120 Hz | | | 1.26 | 0.25 | 3 | UL 778 CSA C22.2 n. 108 |

| | |
|----------------------------------|---|
| Power supply | single-phase 230V/115V tolerance $\pm 10\%$ freq. 50/60 Hz |
| Controller type | Trapezoidal 3 Phase - U/V/W |
| Motor type | BLDC 3 Phase |
| Output | voltage 180 Vac three-phase star (wye) measurement frequency from 30 to 120 Hz (freq. PWM 15 KHz) current Continuous output = at nominal current |
| Environment conditions | operating temperature: 0 °C to 40 °C (measured in close proximity to the inverter) storage temperature: -20 °C to +60 °C ventilation: natural circulation humidity: from 20% to 90% without condensation altitude of installation: max. 2000 m u.s.l. (derating for higher altitudes) protection: IP 20 |
| Type External connections | Digital opto-coupled |
| Alerts | LED (orange): Indication of Supply (permanent) / Alarms (blink). Is located in the center of the main board. Digital output at pin 5: 0V active |
| Protections | electronic protections: over-voltage; under-voltage; over-temperature driver; over-current driver; motor blockage for pump locked rotor motor protection: over-heating in-rush current: limited by NTC component rated 2.5 Ohm |

GUIDE TO SELECTION

| CONTROLLER | MOTOR TYPE | PUMPS | COMPLIANCE |
|------------|------------|-----------|------------|
| FEE1ERW1 | | | 230 Vac CE |
| FEE1DRW1 | 32-35-01 | TMFR/TSFR | 230 Vac UL |
| FEE1ARW1 | | | 115 Vac UL |

Note: Conformal coating is available as optional. It is suggested in application where there is huge changes of ambient temperature and risk of condensation.

Warning

The safety requirements of the TMFR/TSFR device in operation require the installation and the startup to be made by technicians certified by Fluid-o-Tech, in accordance with the general safety regulation valid when working with current and voltage dangerous for people's health.

ELECTRICAL CONNECTIONS

Overview power terminal board

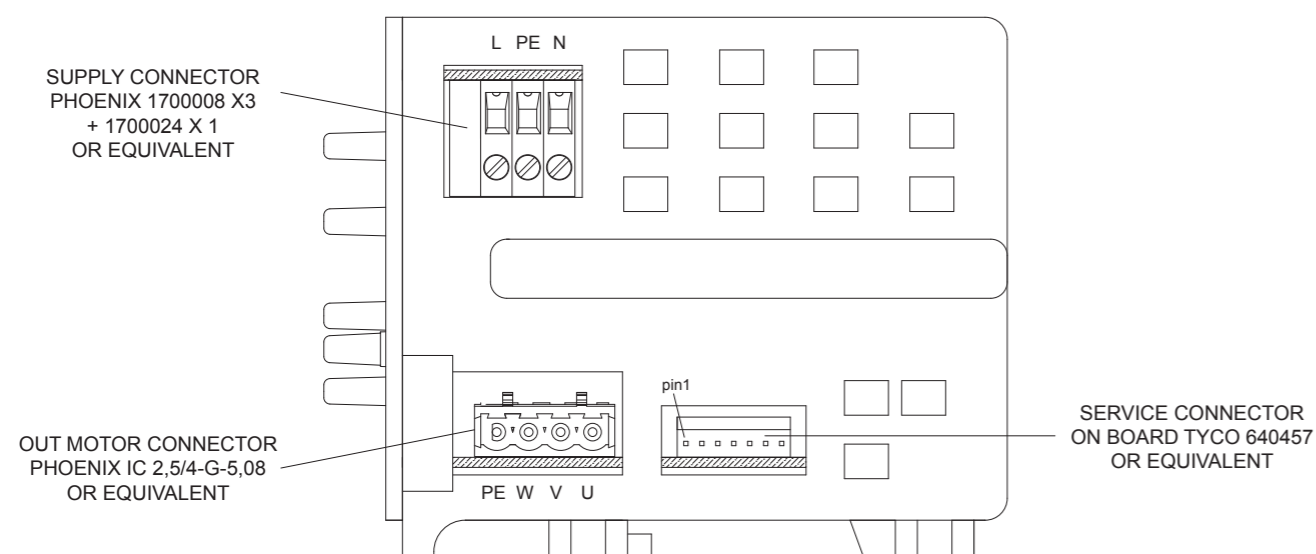

Power supply connections

SUPPLY CONNECTOR
PHOENIX 1700008 X3 + 1700024 X 1
OR EQUIVALENT

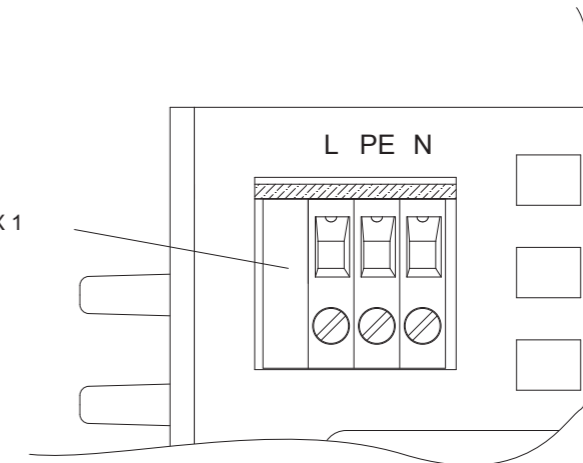

1700008 x 3 Phoenix connector information

Mechanical data:

Pin dimensions 0,8 x 0,8 mm
Pin spacing 5 mm
Hole diameter 1.2 mm
Screw thread M2,5

Tightening torque, min 0.4 Nm
Tightening torque max 0.5 Nm

Connection data:

Conductor cross section solid min. 0.2 mm²
Conductor cross section solid max. 2.5 mm²
Conductor cross section stranded min. 0.2 mm²
Conductor cross section stranded max. 2.5 mm²
Conductor cross section stranded, with ferrule
Without plastic sleeve min.

0.25 mm²
Conductor cross section stranded, with ferrule without plastic sleeve max
1.5 mm²
Conductor cross section stranded, with ferrule with plastic sleeve min.
0.25 mm²
Conductor cross section stranded, with ferrule with plastic sleeve max
1.5 mm²
Conductor cross section AWG/kcmil min. 24
Conductor cross section AWG/kcmil max 14

MOTOR CABLES

Cable for 61000-6-4 Emission standard for industrial environments

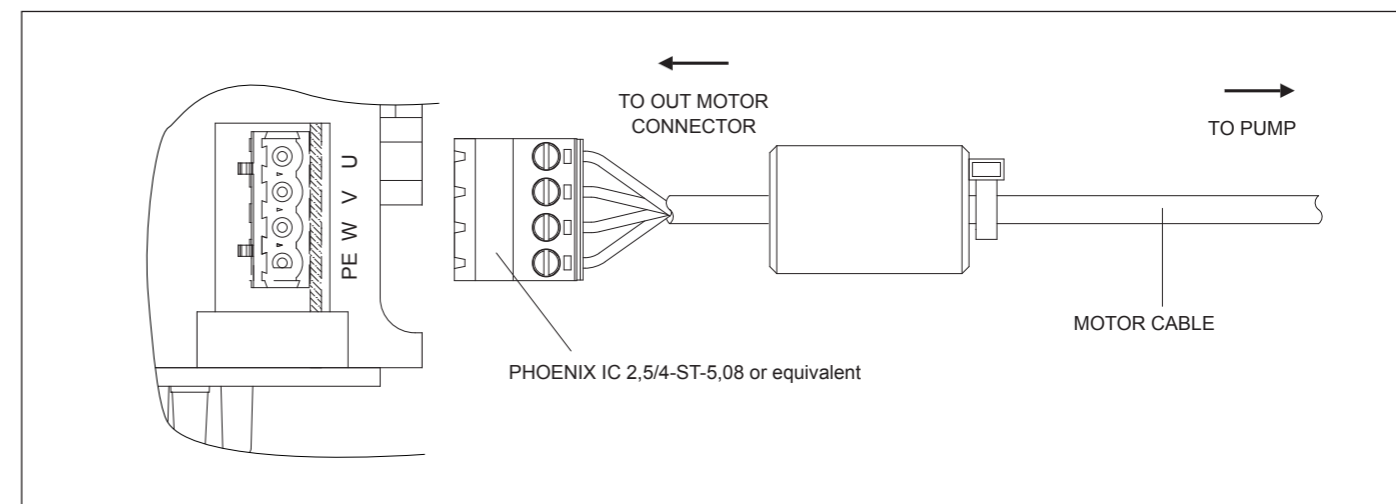

Cable for 61000-6-3 Emission standard for residential, commercial environments (optional)

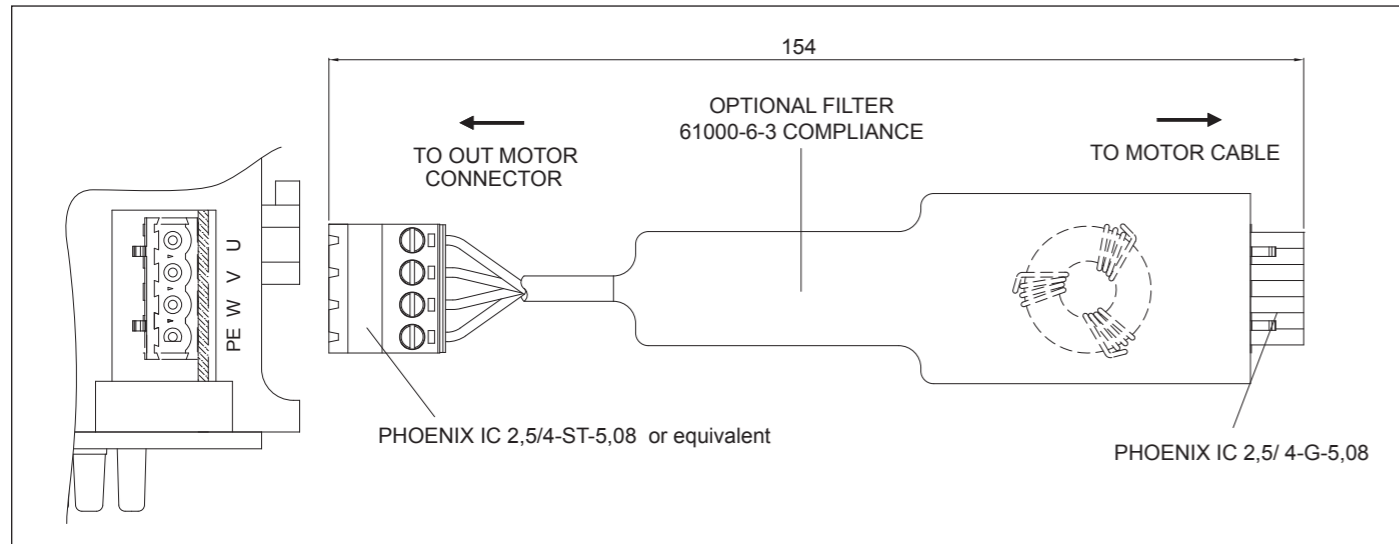

IC 2,5/4-ST-5,08 connector information

| Mechanical data: | |
|---|---|
| Pitch 5.08 mm | Screw thread M3 |
| Dimension a 50.8 mm | Tightening torque, min 0.5 Nm |
| Number of positions 4 | Tightening torque max 0.6 Nm |
| Connection data: | |
| Conductor cross section solid min. 0.2 mm ² | Conductor cross section stranded, with ferrule without plastic sleeve min. 0.25 mm ² |
| Conductor cross section solid max. 2.5 mm ² | Conductor cross section stranded, with ferrule without plastic sleeve max. 2.5 mm ² |
| Conductor cross section stranded min. 0.2 mm ² | Conductor cross section stranded, with ferrule with plastic sleeve min. 0.25 mm ² |
| Conductor cross section stranded max. 2.5 mm ² | Conductor cross section stranded, with ferrule with plastic sleeve max. 2.5 mm ² |
| | Conductor cross section AWG/kcmil min. 24 |
| | Conductor cross section AWG/kcmil max 12 |

FUNTIONALITY MODE/INTERFACE CONNECTIONS

ON-OFF by main power supply and DIP SWITCH SETTINGS

| | |
|--|----------|
| | 1100 rpm |
| | 1500 rpm |
| | 1750 rpm |
| | 2000 rpm |
| | 2500 rpm |
| | 2750 rpm |
| | 3000 rpm |
| | 3500 rpm |

NOTES

• Is present a NTC component (2.5Ω in standard version) that has function of inrush current limiter, it reduce the initial surge of current from the line input to the reservoir capacitor. Is suggested duty cycle with tOFF >100sec (tighten cycle cause it effectiveness reduction).

The switch-on surge, depends from input voltage, ambient and NTC temperature, is approximately 130Amps for some millisecond.

• After the power on of the main supply the TMFR/TSFR unit starts with the dip-switch setting.



Interface connection 4-20mA / 0..5Vdc, Limited energy circuit, 15W or less.

ON-OFF OTPO on DIP SWITCH SETTINGS

MODALITA' DIGITAL OPTO ON/OFF

| DIP STATUS | ON/OFF OPTO (SERVICE Connector) | ANALOG INPUT (SERVICE Connector) | FUNCTION |
|------------|---------------------------------|----------------------------------|-----------------|
| | 0V (0) | X | MOTOR OFF |
| | 5 to 24 V (1) | X | DIP SWITCH MODE |

SERVICE CONNECTOR TYCO 3-643814-7 OR EQUIVALENTE

OPTO DIGITAL on EXTERNAL DIP SWITCH SETTINGS.

MODE OPTO DIGITAL (EXTERNAL DIP)

| DIP STATUS | ON/OFF OPTO (SERVICE Connector) | ANALOG INPUT (SERVICE Connector) | FUNCTION |
|------------|---------------------------------|----------------------------------|----------|
| | 0V (0) | 0V | 1100 rpm |
| | 0V (0) | 5 to 24 V (1) | 1500rpm |
| | 5 to 24 V (1) | 0V | 2000 rpm |
| | 5 to 24 V (1) | 5 to 24 V (1) | 3500 rpm |

SERVICE CONNECTOR TYCO 3-643814-7 OR EQUIVALENTE

NOTES

If necessary to drive the controller with a voltage bigger then 5V, for example 12V or 24V, is necessary to put in series to connection a 2200Ω 1/4W resistance.

ANALOG COMMAND with ON-OFF OPTO DIGITAL.

MODE ANALOG IN VOLTAGE COMMAND (0-5 V)

CONNETTORE DI DIAGNOSI TYCO 3-643814-7 O EQUIVALENTE

MODE ANALOG IN PWM COMMAND (100-10.000 Hz)

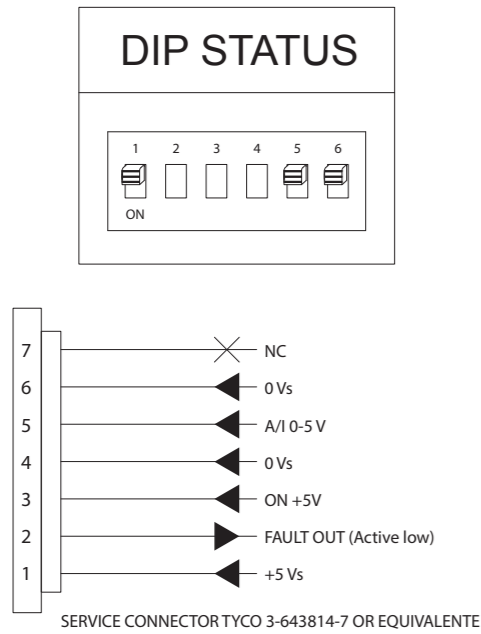

MODE ANALOG IN CURRENT COMMAND (4-20 mA)

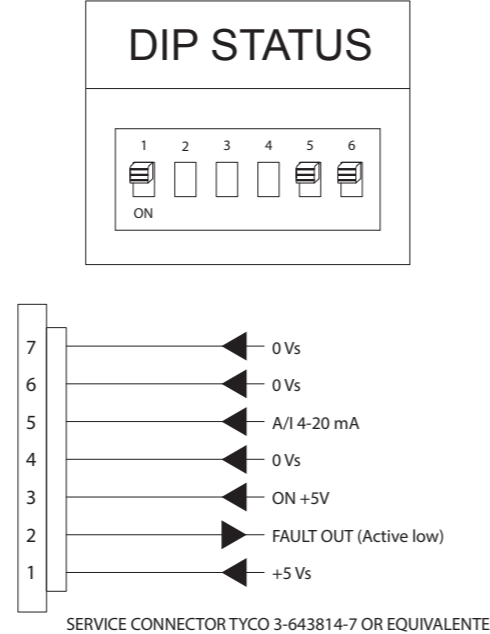

NOTE
 PWM frequency signal (100 to 10000 Hz) with amplitude 5V (tOFF = 0V tON = 5V), 10% to 95% duty cycles range. This signal, with the characteristic described on pin 5, is interpreted as a real Analog. Input (Voltage). Differences in terms of amplitude tON and, in value tOFF different from 0V, modify speed value.

Instruction for assembly the Interface Connector MTA 100 (3-640440-7)

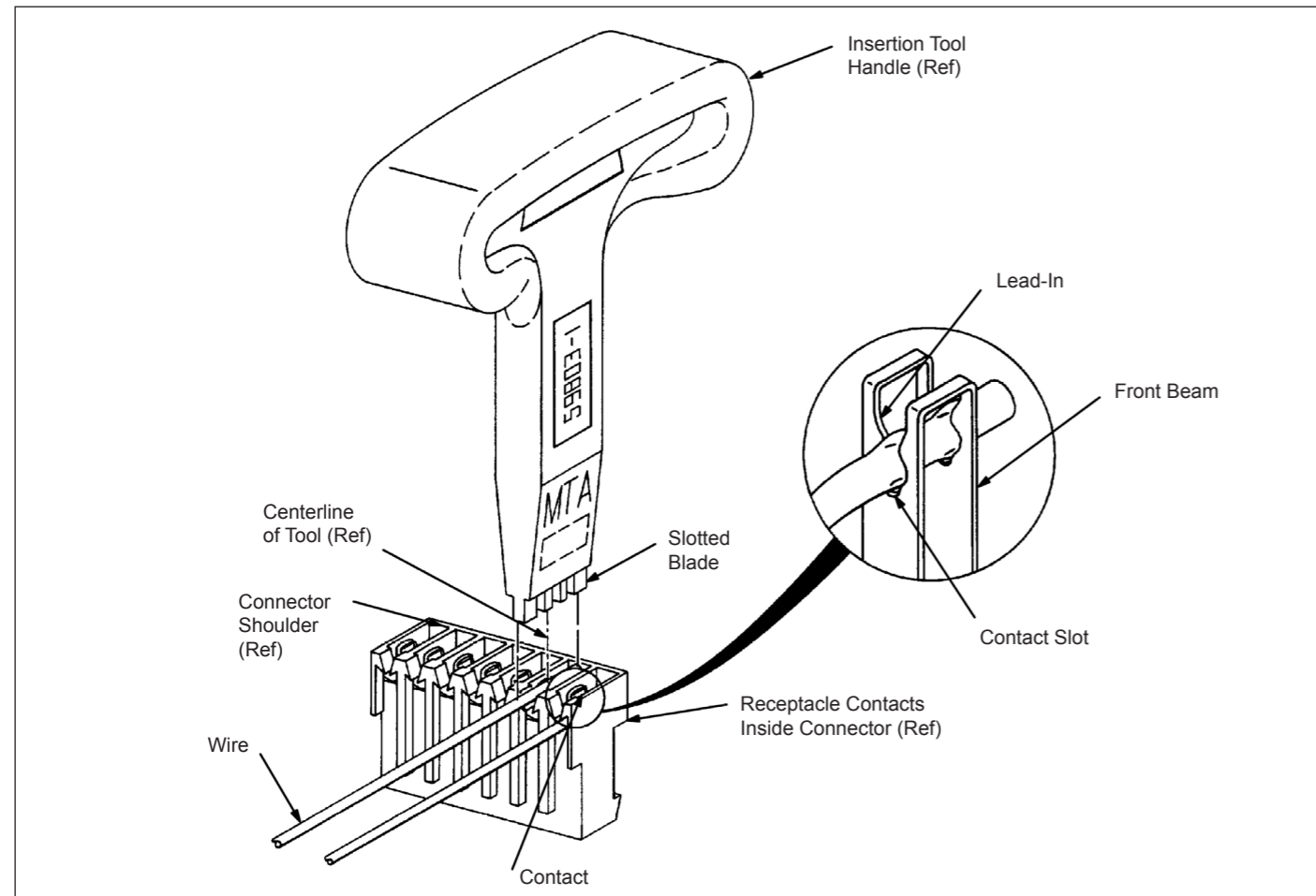

NOTE Insertion tool is Tyco Electronics P/N 59803-1

FAULT SIGNAL

The TMFR/TSFR driver has a fault signal in OR function which includes the alarms (Autoresettable and Permanent):

- 1 - Over-voltage;
- 2 - Under-voltage;
- 3 - Over-temperature;
- 4 - Start-up;

- 5 - Rotor blocked;
- 6 - Module Fault (hardware)
- 7 - Over-current power;
- 8 - Over-current hardware limit (50% more than the over-current power)

In the picture below there is the diagram with the electronic characteristic of the Fault Signal. It is active when low (0V). When the TMFR/TSFR unit runs correctly the FAULT signal is high (5V).

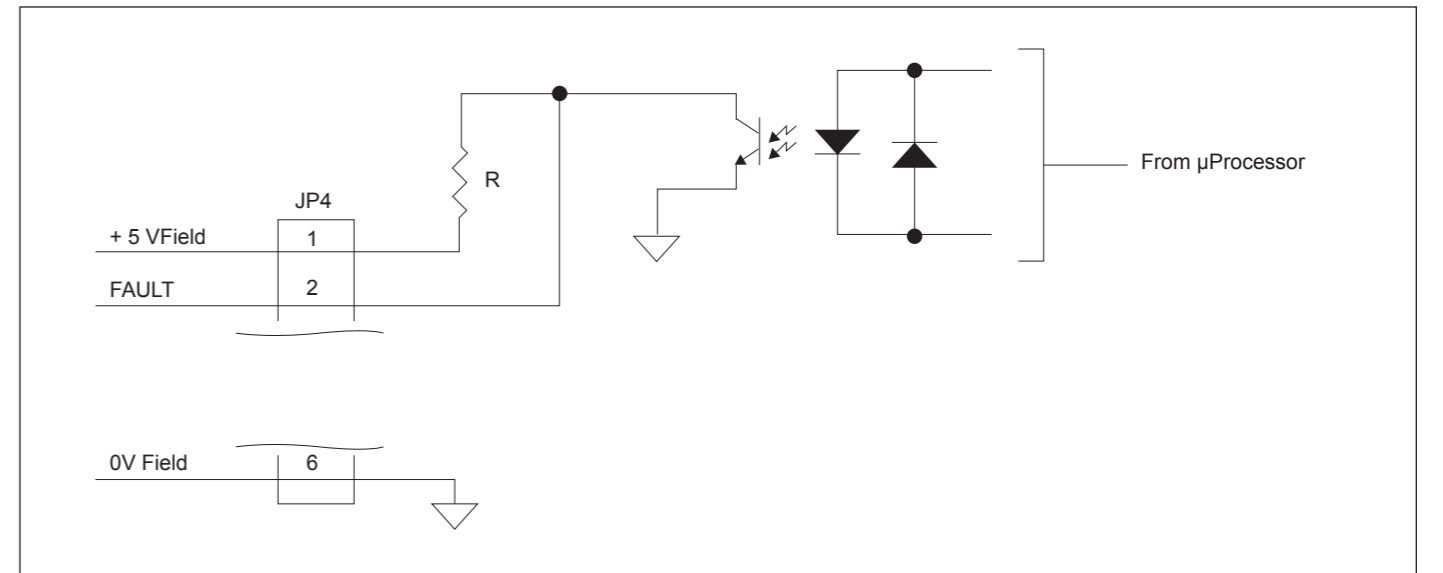

AUTO RESETTABLE ALARMS

Over-voltage

It is active when main power supply is:
 > 135 Vac for nominal 115 Vac;
 > 245 vac for nominal 230 Vac.

It is inactive when main power supply is:
 < 125 Vac for nominal 115 Vac;
 < 245 Vac for nominal 230 Vac.

Under-voltage

It is active when main power supply is:
 < 50 Vac for nominal 115 Vac;
 < 100 vac for nominal 230 Vac.

It is inactive when main power supply is:
 > 60 Vac for nominal 115 Vac;
 > 120 Vac for nominal 230 Vac.

Over-temperature (controller)

It is active when the power module temperature is > 90°C (194°F).
 It is inactive when the power module temperature is < 80°C (176°F)
 When an auto resettable alarm is active, the unit switch off, the Fault signal is low (0V) and the alert LED flash. When an auto resettable alarm cease the Fault signal goes high (5V), alert LED is steady and the unit restart with set settings, if ON signal is present.

SEMI-PERMANENT ALARMS

Start-up

If the starting sequence of the unit fails, the driver opens the power module and passes into blocking state. The Fault signal is low (0V) and the alert LED blinks.

Rotor blocked

If the pump rotation is blocked, the driver opens the power module and it passes into blocking state.

Module Fault (hardware)

If in the pump rotation a peak of the current appears in the module. The module opens the outputs and passes in blocking state.

Over-current power

If in the pump rotation a peak of the current appears for an overload (more 400 W), the driver opens the power module and passes in blocking state.

Over-current hardware limit (50% more than the over-current power)

If in the pump rotation a peak of the current appear for an overload (more 400 W), the driver opens the power module and it passes in blocking state. If a semi-permanent alarm occur, the inverter attempt to restart for 20 times (around 20 sec.). The counter of attempt reset to zero when unit work for more then 16 sec..

When counter reach the 20 attempts , the alarm became permanent, the Fault signal goes low (0V), the alert LED blinks and for restarting the unit it is necessary one of these two operations:

- Turn OFF the main power supply and after Turn ON the main power supply;
- Turn OFF the ON/OFF digital signal and Turn ON the ON/OFF digital signal.

These two operations RESET the driver. If the cause of the block is removed the unit will start removing the Fault signal.

TYPICAL DRIVER BEHAVIOUR WHEN IN OVERLOAD

The driver, when the power output reach the maximum value (more then 375W), it decrease and modulate automatically the rotational speed, up to minimum speed, for maintaining the maximum load within 375W. If it couldn't modulate it enter in "over-current power" semi-permanent alarm mode.

ELECTRIC INSTALLATION

The power connection wires must be of appropriate section, in proportion to the current absorbed in the specific application.

The cable shield must be connected to the ground both on the inverter and on the motor side.

The power cables must be separated from the control cables; it is forbidden passing them in the same raceway. It is important to keep separated the motor cable from the cable going to the electronic.

MECHANICAL INSTALLATION

The TMFE2 controller and TMFR motor+pump unit are cooled by forced or natural ventilation. For this reason the unit must be mounted taking into account a 40 mm space around it and, in correspondence to the heat sink, 150 mm on top and underneath in order to grant the free circulation of cooling air. In case of mounting more units stacked it is necessary to leave a minimum of 300 mm vertically between the 2 units. The air must be free from dust or corrosive substances. In case this is not possible, the heat sink must be periodically cleaned. Condensation of vaporized fluids must be avoided at all times. The environmental humidity must not exceed 90%. The ambient temperature in the chassis of the machine must not exceed 40 °C; it is otherwise necessary a derating of the device or a forced ventilation to avoid stagnation of air.

The controller, the unit and electrical connection must be protected from fluids drips that could damage unit and cause short circuit.

Hydraulic Note

Electric/Manual valves in pump inlet/outlet circuit have to be opened before TMFR/TSFR start-up. If the pump is equipped with a relief valve (by-pass), the valve will work, in case of accidental

overpressure, in order to limit the peak pressure, by an internal recirculation of the fluid. Thanks to the magnetic coupling the pump does not need a mechanical seal in order to prevent leakage.

This eliminates the problems connected to the use of a mechanical seal. The maximum pressure depends on the pump model and it decreases with the increase of the flow rate.

The outlet pressure must not exceed 20 bar/290 psi in any case.

REPLACING THE PUMP

In order to replace the pump it is necessary to remove the three screws on the front end of the motor. Once these screws are removed it is sufficient to pull the pump back. During this operation it is necessary to verify that the magnet cap does not make in contact and damage the stator winding. The pump magnet is very powerful, it is therefore important to keep it far from pacemakers, credit cards, watches and all equipment sensitive to magnet fields. It is also necessary to replace the pump in a clean environment, as any magnetic particles in close proximity to the magnet will be attracted from it and it might cause the pump to fail prematurely.

After each manipulation is necessary to re-conduct safety tests (disconnecting controller), as prescribed in EN-60335 and UL-1004, for this reason is recommended that operations are conducted by Fluid-o-Tech qualified operators.

STANDARD MAINTENANCE

The Fluid-o-Tech TMFR/TSFR series units maintenance and replacement of parts subject to wear have to be done by a qualified technician. Periodic cleaning of the circuit and filters is advisable in order to avoid cavitation and wear of the internal components.

