

# FS14

## Miniature Plastic Float Level Switch For Horizontal Mounting

- compact design
- only one mechanically moveable component
- mounts horizontally into tankwall
- PP or Nylon version available

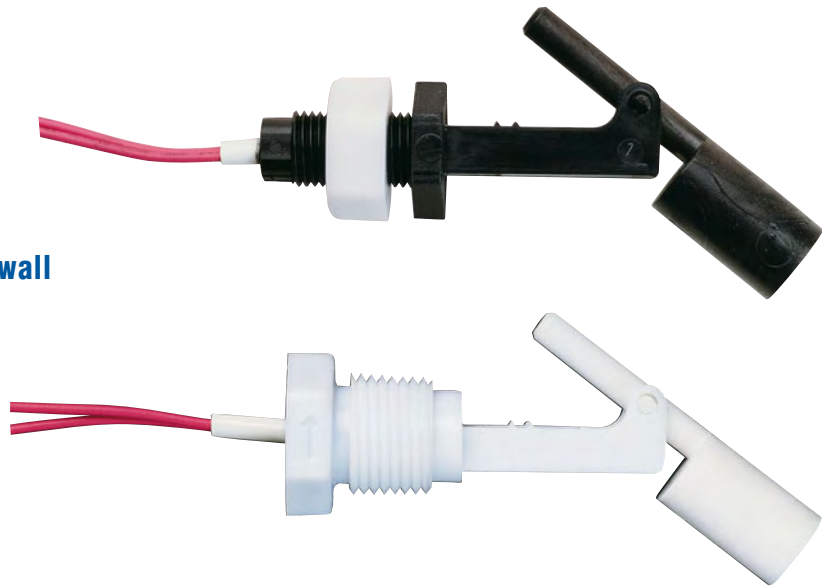

### Description

The level switches model FS14 work according to the magnetic float principle. The float is lifted upwards by the rising liquid level in the tank until the magnetic field of the integrated permanent magnet activates a Reed contact. Depending on the way the level switch is mounted this contact may work as a N/O or a N/C switch.

### Applications

The float level switches FS14 are designed to monitor the level of nearly all liquids which do not affect the used materials, for example as HIGH- or LOW-alarms or for controlling valves and pumps.

In North & South America Find Our Products On-Line at Clark Solutions:

[www.clarksol.com](http://www.clarksol.com)



 **PKP Process Instruments Inc.**  
10 Brent Drive · Hudson, MA 01749  
Tel: 978-212-0006 · Fax: 978-568-0060  
Email: [sales@clarksol.com](mailto:sales@clarksol.com) · Internet: [www.clarksol.com](http://www.clarksol.com)

 **PKP Prozessmesstechnik GmbH**  
Borsigstraße 24 · D-65205 Wiesbaden  
Tel: 49 (0) 6122-7055-0 · Fax: 49 (0) 6122-7055-50  
Email: [info@pkp.de](mailto:info@pkp.de) · Internet: [www.pkp.de](http://www.pkp.de)

## Versions

- Low-cost level switch made from PP or Nylon
- Threaded connection R 1/4" or 1/2" NPT

## Dimensions

FS14.1

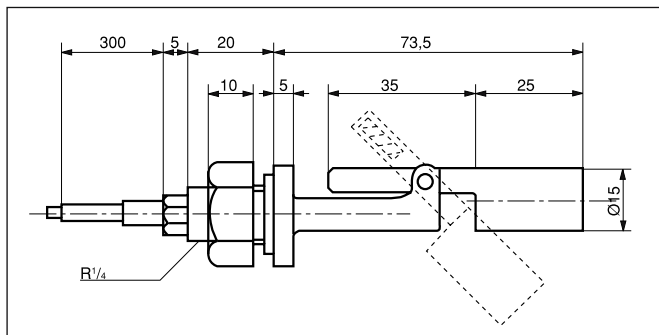

FS14.2

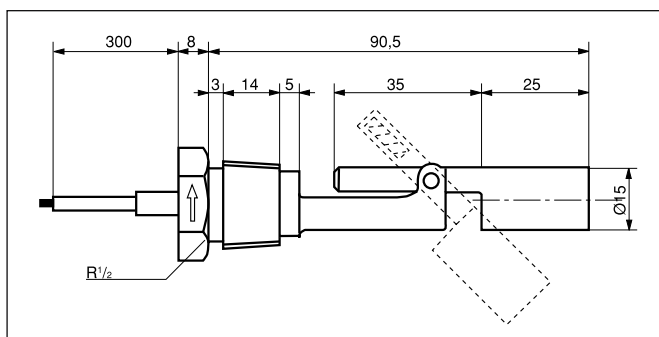

## Mounting and contact functions

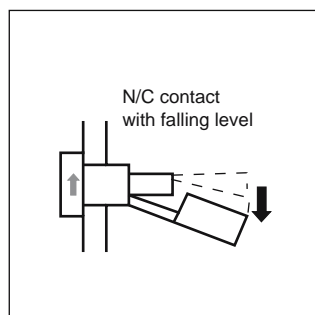
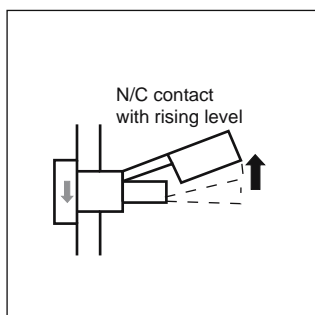
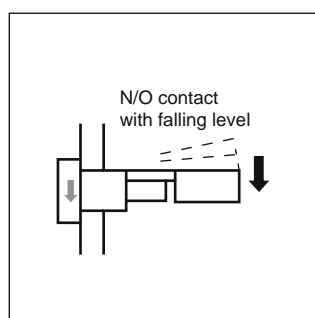
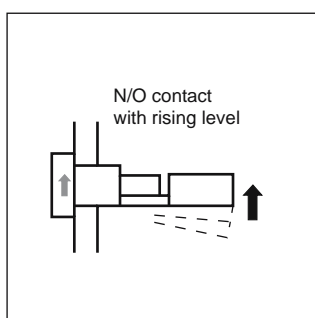

## Ordering Code

Order No.

FS14. 1. 1. 2.

Miniature float level switch

Connection:

1 = R 1/4" male thread

2 = 1/2" NPT male thread

Material:

1 = Polypropylen

2 = Nylon

Contact rating:

2 = 300 V DC/AC, 0.5 A, 50 VA

## Technical Specifications

Connection cable: 0.3 m of PE wire

Threaded connection:

FS14.1: R 1/4" male with nut

FS14.2: 1/2" NPT male

Material:

FS14.x.1: PP

FS14.x.2: 6-Nylon

Contact function:

N/C or N/O (300V, 0.5A, 50VA)  
with rising level, depending on  
mounting

max. pressure:

atmospheric

max temperature:

FS14.x.1: -10 ... +80°C

FS14.x.2: -10 ... +110°C

min. S.G. of medium:

0.7 kg/l

In North & South America Find Our  
Products On-Line at Clark Solutions:  
[www.clarksol.com](http://www.clarksol.com)

PKP Prozessmesstechnik GmbH

Borsigstraße 24 · D-65205 Wiesbaden  
Tel: 49 (0) 6122-7055-0 · Fax: 49 (0) 6122-7055-50  
Email: [info@pkp.de](mailto:info@pkp.de) · Internet: [www.pkp.de](http://www.pkp.de)



PKP Process Instruments Inc.

10 Brent Drive · Hudson, MA 01749  
Tel: 978-212-0006 · Fax: 978-568-0060  
Email: [sales@clarksol.com](mailto:sales@clarksol.com) · Internet: [www.clarksol.com](http://www.clarksol.com)

