

GPI Pulse Out with Display

Owner's Manual

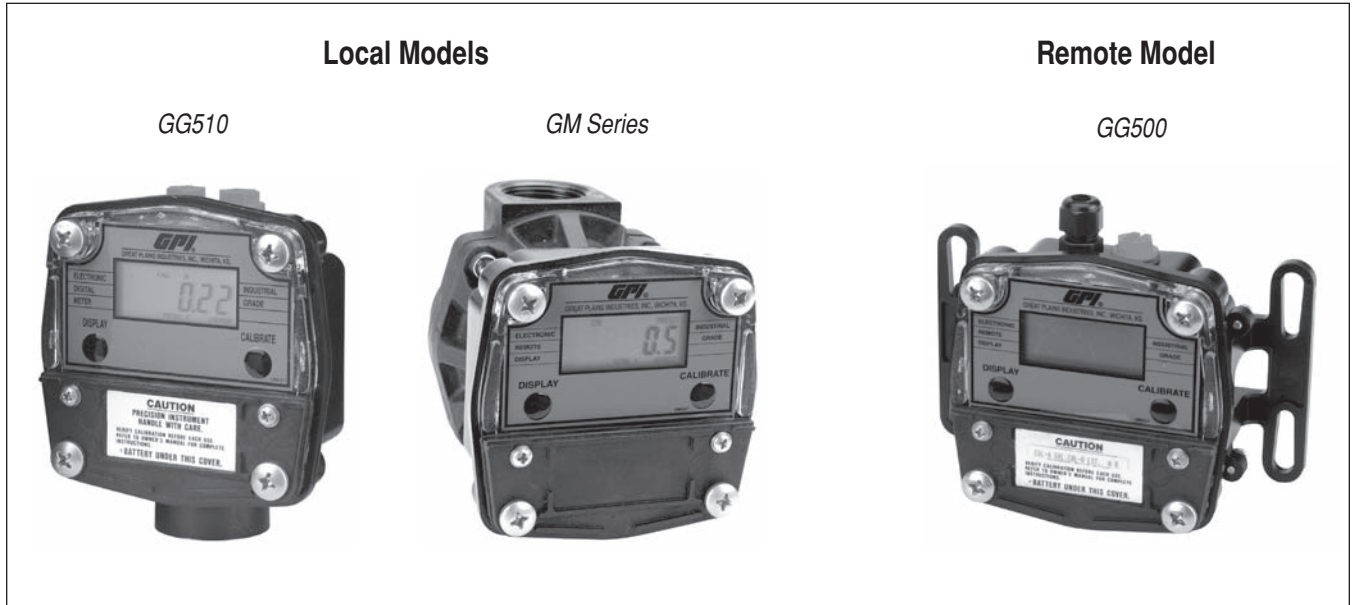

To the owner...

Congratulations on receiving your GPI Standard Display. We are pleased to provide you with a product designed to give you maximum reliability and efficiency.

Our business is the design, manufacture, and marketing of liquid handling, agricultural, and recreational products. We succeed because we provide customers with innovative, reliable, safe, timely, and competitively-priced products. We pride ourselves in conducting our business with integrity and professionalism.

We are proud to provide you with a quality product and the support you need to obtain years of safe, dependable service.



President
Great Plains Industries, Inc.

TABLE OF CONTENTS

General Information.....	2
Safety Instructions.....	2
Installation	2
Wiring	3
Operation.....	6
Calibration	6
K-Factor Entry Method Calibration Procedures	6
Correction Factor Method Field Calibration Procedures	7
Configuration.....	7
Maintenance.....	8
Troubleshooting.....	8
Illustrated Parts Drawing	9-10
Specifications.....	11
Dimensional Drawings.....	12
Service.....	13
WEEE Directive.....	13

GENERAL INFORMATION

This manual will assist you in operating and maintaining the GPI electronics supplied with your GPI meter or as an accessory unit on both local and remote models. The GPI Electronics can be used in indoor or outdoor applications where occasional exposure to moisture is common.

- The Pulse Out with Display is available in two versions. One indicates flowrate in units/minute and one in units/hour. Both indicate flow totals in gallons and litres.
- The Pulse Out with Display can be used on all GPI models, including the Precision G series, the Industrial Grade G2 series, the Commercial Grade A1 series, and the positive displacement GM Series oval gear meters.
- The Pulse Out with Display can be battery powered or externally powered.

Product differences in this manual are identified by either, **Local** or **Remote** as necessary.

If a meter was purchased with this display then it will come calibrated from the factory for gallons "GAL" and litre "LTR". Field calibration is also available.

If the unit was purchased as an accessory or remote, the calibration has not been entered and the end user will be required to calibrate the display.

SAFETY INSTRUCTIONS

- When measuring flammable liquids, observe precautions against fire or explosion.
- When working in hazardous environments, always exercise appropriate safety precautions.
- Be sure O-rings and seals are kept in good repair.
- When applying power, use DC power **only!**
- Disconnect external power before attaching or detaching input or output wires.

INSTALLATION

⚠ CAUTION

Installation should be performed only by qualified personnel, and in accordance with local governing regulations.

The following installation guidelines are separated by meter series and mounting type.

Precision G Series:

- **Local** – The GG510 Pulse Out with Display mounts directly to the 1 inch MNPT conduit connector.
- **Remote** – The GG500 Pulse Out with Display connects via an output cable as shown in the Wiring Diagram.

Industrial Grade G2 Series:

- **Local** – The GG510 Pulse Out with Display requires the GPI Conduit Connector Kit (Part #113437-01) for local mounting to the G2 series meter.
- **Remote** – The GG500 Pulse Out with Display connects via an output cable as shown in the Wiring Diagram.

Commercial Grade A1 Series:

- **Local** – The GG510 Pulse Out with Display requires the GPI Conduit Connector Kit (Part #113437-01) for local mounting to the A1 series meter.
- **Remote** – The GG500 Pulse Out with Display connects via an output cable as shown in the Wiring Diagram.

GM Oval Gear Series:

- **Local** – The Pulse Out with Display is mounted directly to the oval gear meter housing.
- **Remote** – The GG500 Pulse Out with Display connects via an output cable as shown in the Wiring Diagram.

Remote Installation

Choose a mounting location suitable for the Display. The ideal mounting location is where the:

- Flowmeter is as close as possible.
- Mounting surface has minimal vibration.
- Ambient temperature is 0° F to 140° F (-18° C to 60° C).
- Cable lengths are minimal.

Avoid mounting locations where the Display is:

- Subject to constant exposure to water or other liquids (occasional low-pressure splashing will not harm unit).
- Subject to > 5g shock loading.
- Facing the sun directly for long periods of time.

Mount the GPI Display Remote using bolts, screws or standard U-bolts for pipes. Mounting options include:

- Wall
- Pipe
- Meter (1 inch FNPT conduit connection required)

Some products come with 20 feet of shielded cable. GPI offers an optional cable kit with 100 feet of cable (see spare parts list). When wiring longer lengths of cable, be sure to connect the shield to LOCAL-COM **only!** (Multiple shield connections may cause ground-loop problems. Some trial and error may be needed because of the wide variety of user conditions.

Try to keep cable lengths short. Individual installation sites vary widely, contact GPI Customer Service with questions regarding your specific needs.

WIRING

This manual refers to various models of GPI flowmeters. Determine what type of input the electronics will receive and what type of output, if any, you require. If the unit is not already wired, use the diagrams found in the wiring diagrams section to correctly wire the system.

Connecting the Equipment

1. Remove the faceplate by removing the four corner screws.
2. Attach wiring from your equipment according to the following terminal connections and wiring instructions, depending on your circumstances. (See Terminal Connections below)

The display may be powered by battery, externally powered or both. When both are used (external power terminal as primary with the battery terminal as back up) the batteries should last up to 5 years. Connection and disconnection of either power input, while the other is active will not interrupt operation of the display.

CAUTION

Determine maximum power supply voltage after determining maximum allowable voltage of all electronic devices in the system.

TERMINAL LOCATIONS

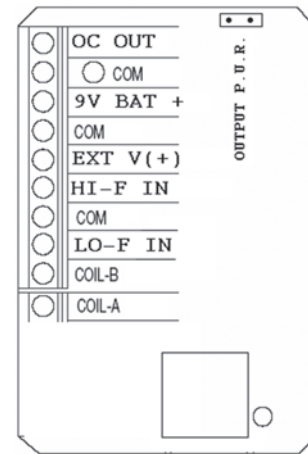

9V_BAT+ Battery, 6.5V to 20V

EXT_V(+) External Power, 7V to 30V

**COIL_B /
COIL_A**

Any magnetic (variable-reluctance) pickup coil can drive this input. Minimum signal amplitude is 10 mV P-P. Maximum recommended signal amplitude is 1V P-P. Shielded cable may be used to increase distance.

HI-F_IN

Either open-collector or active-drive signals are accepted. If active-drive, signals of 5V to 12V P-P amplitude are acceptable. Maximum frequency is approximately 1000 Hz. *Note: Optional to route a reed-switch signal directly to this input.*

LO-F_IN

A reed switch may be connected directly between this terminal and any **COM** terminal. Maximum frequency is approximately 150 Hz.

OC_OUT

- This is an open-collector or current-sinking output when NO JUMPER is attached at OUTPUT P.U.R. location. It can sustain closed-circuit current of up to 200 mA and open-circuit voltage of up to 60V.
- This is an active-drive output when the JUMPER (supplied) is attached at location OUTPUT P.U.R. The JUMPER applies an internal 10K Ohm resistor as a "pull-up" to the regulated power supply of 5.5V.
- The output ground circuit may be connected to any **COM** terminal.
- Do not use JUMPER if operating from a battery; it will cause significantly increased system current consumption.
- **CAUTION:** Only use JUMPER when the receiving equipment has a active-drive input with 5V or less.

COM

All COM terminals are internally connected and may be used either as NEGATIVE power supply terminals or return terminals for any inputs or outputs.

POWER

9V Battery (included)

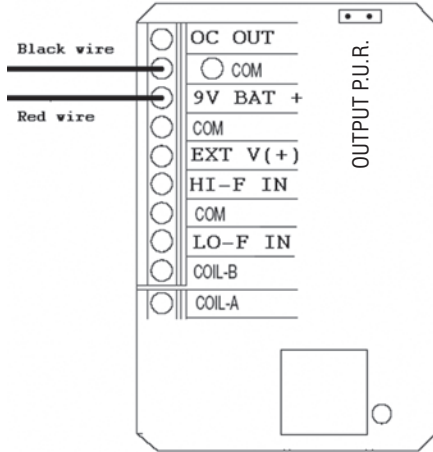

Connect battery (included) red wire (+) to **9V_BAT+** terminal.
 Connect battery (included) black wire (-) to any **COM** terminal.

External Power

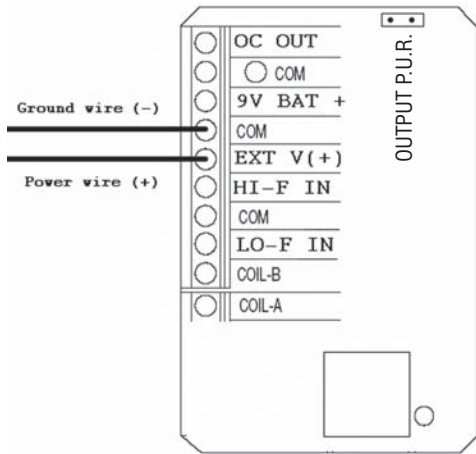

Connect power wire (7-30 VDC) to **EXT_V(+)** terminal.
 Connect ground wire to any **COM** terminal.

SIGNAL INPUT

Sine Wave (coil)

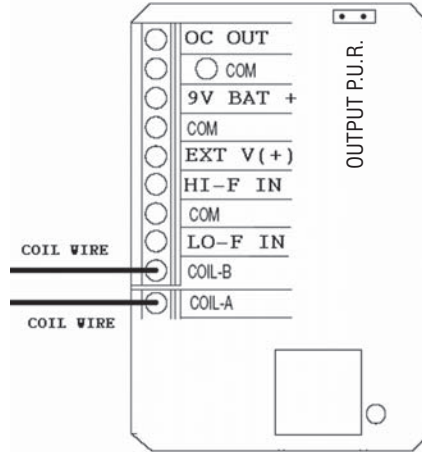

Connect either coil wire to **COIL_A** terminal.
 Connect other coil wire to **COIL_B** terminal.
 Connect shield cable, if any, to any **COM** terminal.
 NOTE: Leave meter side of shield wire unconnected.

Square Wave (active drive)

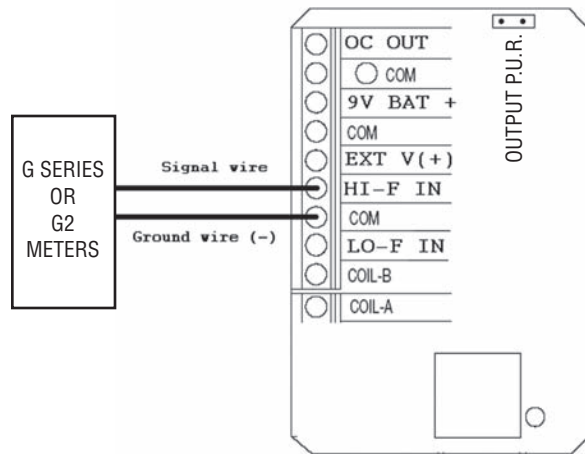

Connect signal wire to **HI-F_IN** terminal.
 Connect ground wire to any **COM** terminal.

Contact Closure (reed switch)

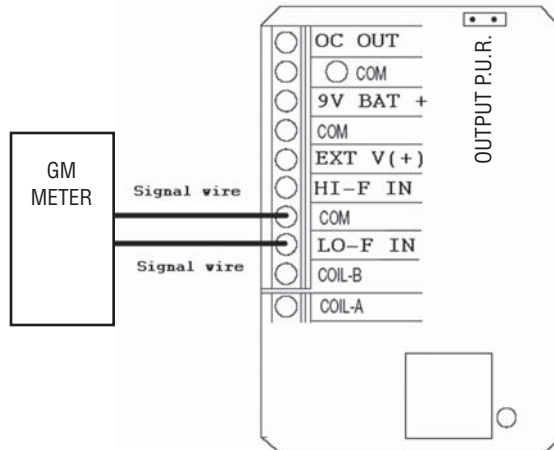

Connect either wire to **LO-F_IN** terminal. Optional to connect to **HI-F_IN**.
 Connect other wire to any **COM** terminal.

continued on next page

SIGNAL INPUT

Open-Collector

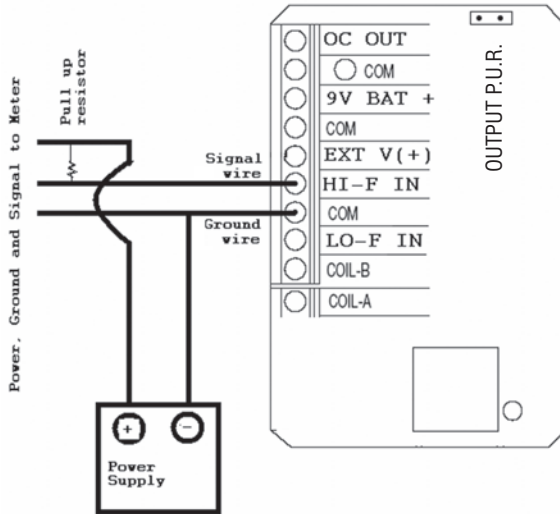

Connect signal wire to **HI-F_IN** terminal.
 Connect ground wire to any **COM** terminal.
 Connect 1K pull up resistor between (+) power wire and signal wire.

Open Collector with External Power to Display

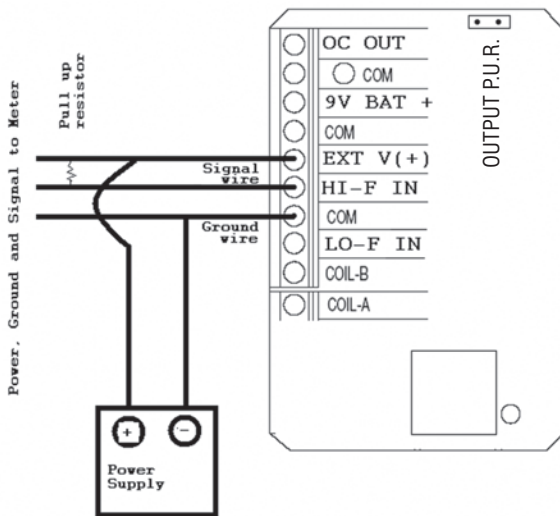

Connect signal wire to **HI-F_IN** terminal.
 Connect ground wire to any **COM** terminal.
 Connect power wire (+) to **EXT_V (+)** terminal.
 Connect 1K pull up resistor between (+) power wire and signal wire.

continued on next column

SIGNAL OUTPUT

Open Collector

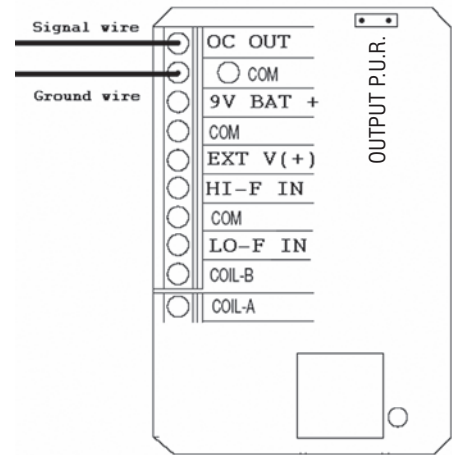

Connect signal wire to **OC_OUT** terminal.
 Connect ground wire to any **COM** terminal.
 NOTE: Jumper should **not** connect pins marked Output P.U.R.

Active-Drive Output

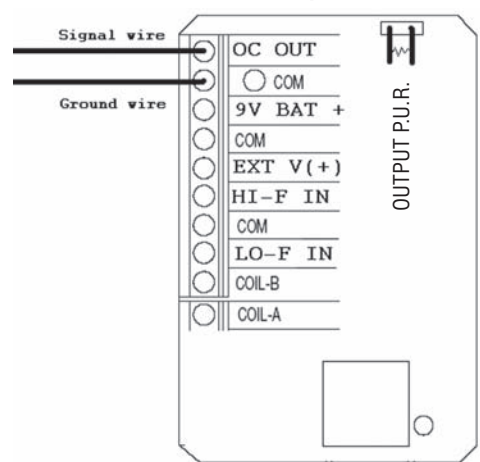

Connect signal wire to **OC_OUT** terminal.
 Connect ground wire to **COM** terminal.
 Place JUMPER (supplied) over both pins marked OUTPUT P.U.R.

NOTE: Multiple COM terminals are provided for convenience in making connections.

OPERATION

Computer Display

All operations are reflected in the LCD readout. The large center digits indicate amounts, where smaller words or “icons” located above and below indicate specific information regarding totals, flow, calibration and units of measure.

Activate the Meter

Computer is on continuously and always ready to perform. The computer is powered by a field replaceable battery. When display becomes dim, faded or the low battery message appears (see below), the battery needs to be replaced. Reference the Maintenance Section for details.



Batch and Cumulative Totals

The computer maintains two totals. The Cumulative Total provides continuous measurement and cannot be manually reset. The Batch Total can be reset to measure flow during a single use. The Cumulative Total is labeled TOTAL 1, Batch Total is labeled TOTAL 2 BATCH.

When the Cumulative Total reaches a display reading of 999,999 the computer will highlight an X10 icon. This indicates to the operator that a zero must be added to the 6 digits shown. When the next rollover occurs, the computer will highlight an X100 icon. This indicates to the operator that two zeros must be added to the 6 digits shown.

Press the DISPLAY button briefly to switch between the TOTAL 1, TOTAL 2 BATCH and FLOWRATE. Press DISPLAY briefly to display the TOTAL 2 BATCH. Hold the DISPLAY button for 3 seconds to reset the Batch Total to zero.

When fluid is flowing through the meter, a small propeller icon is highlighted.

Flowrate Feature

To use this feature, press and release DISPLAY until FLOWRATE icon appears. The factory set time base will be highlighted to the right of FLOWRATE (M = minutes, H = hours, D = days). When FLOWRATE is invoked, the display will be indicating rate of flow.

Factory and Field Calibration

All calibration information is visible to the user as icons on the top line of the display, above the numeric digits.

All units are configured with a “factory” calibration. Both gallons and litres are available (“GL” or “LT” will be displayed). While holding the CALIBRATE button, briefly press DISPLAY to toggle between gallons and litres. This factory calibration (indicated with FAC) is permanently programmed into the computer and is not user adjustable.

NOTE: Your computer may have other units of measure programmed into it. If so, holding the CALIBRATE button and momentarily pressing the DISPLAY button will toggle through all factory set units. Other possible units are: IGL (imperial gallon), QT (quart), CF (cubic feet), CM (cubic meter), BL (42 gal. barrel), CC (cubic centimeter) or OZ (ounce).

Switching between different units will not corrupt the Total's contents. For example, in GL mode, the computer totalizes 10.00 gallons, if the user switches to LT mode, the display will read 37.85 litres (the same volume, different unit).

The “field” calibration may be set by the user, and can be changed or modified at any time using the calibration procedure described in the Calibration Section. Totals derived from the field calibration are invoked when the FAC icon is no longer visible on the top line of the display.

CALIBRATION

Field Calibration Procedures (K-Factor Entry Method)

If the display was purchased as an accessory or remote, then the field calibration method set at the factory is K-factor Entry method.

This method allows the user to key in a single point K-factor value that represents the meter it will be used with. K-factor values for specific meters can be found on the meter itself, in Table 1 or www.gpimeters.net.

1. To field calibrate, press and hold both CALIBRATE and DISPLAY buttons for about 3 seconds until you see FLdCAL. Release both buttons and you will see Kxxxx.x (where “x” represents the current field-cal k-factor value). You are now in the field calibration mode.
2. The far left digit will be blinking. The DISPLAY button can then be pressed to select the digit location and the CALIBRATE button can be pressed to scroll the desired value at the blinking position. Edit the K-factor shown to the desired value. Acceptable K-factor range is 0000.1 to 9999.9.
3. After the new value has been entered, momentarily press and release both buttons. “CALEND” will be momentarily displayed. Unit is now ready for use.
4. Notice that the upper display line, the “FAC” icon and all the units of measure have disappeared.

Alternate units of measure are not selected when the meter is operating with field calibration. This calibration is a unique single-point calibration for the meter and/or application.

NOTE: To return to factory calibration (FAC), press and hold both CALIBRATE and DISPLAY buttons for about 3 seconds, until FACCAL is displayed. Then release buttons. Unit should return to normal operation and FAC icon is visible.

NOTE: If the field calibration mode is entered and NO fluid is dispensed, then upon leaving, the computer will use data from the last successful field calibration.

TABLE 1

Model	Size	Typical K-Factor (pulses/gallon)
G2_05	1/2 in.	2500
G2_07	3/4 in.	1100
G2_10	1 in.	560
G2_15	1-1/2 in.	215
G2_20	2 in.	100
G2P05	1/2 in.	2400
G2P10	1 in.	540
G_T-051	1/2 in.	10000
G_T-075	3/4 in.	3750
G_T-100	1 in.	896
G_T-150	1-1/2 in.	350
G_T-200	2 in.	181
G_T-300	3 in.	50
G_P-050	1/2 in.	10000
G_P-051	1/2 in.	10000
G_P-075	3/4 in.	3750
G_P-100	1 in.	896
G_P-150	1-1/2 in.	340
G_P-200	2 in.	181
GM001	1/8 in.	5855
GM002	1/4 in.	3785
GM003	1/4 in.	1514
GM005	1/2 in.	424
GM006	3/4 in.	197
GM007	1 in.	197
GM010	1 in.	136
GM015	1-1/2 in.	55
GM020	2 in.	25

**Field Calibration Procedures
(Correction Factor Method)**

If the display was purchased with a meter body then the field calibration method set at the factory is the Correction Factor method.

This method allows the user to tweak the factory calibration by a percent that represents application, fluid or plumbing differences.

1. To calibrate, press and hold the CALIBRATE and DISPLAY buttons for about 3 seconds until you see FLdCAL. Release both buttons and you will see CF-00.0. You are now in the field calibration mode and values from -99.9% to +99.9% can be entered.
2. The +/- position appears either as an “underscore” character for plus, or as a “hyphen” character for minus. The DISPLAY button selects the position and the CALIBRATE button toggles this character.

3. The DISPLAY button can then be pushed to select the numeric positions. Press the CALIBRATE button to scroll from 0 to 9. Enter the percentage of change you want the display to correct. When satisfied with the value, press both CALIBRATE and DISPLAY buttons simultaneously. CALEnd will be displayed and unit will go back to normal operation, less the FAC (factory calibration) icon.
4. All enabled units-of-measure remain visible and selectable – the entered correction will be applied to all enabled units.
5. To return to factory calibration (FAC), press and hold both CALIBRATE and DISPLAY buttons for about 3 seconds until FACCAL is displayed. Then release buttons. Unit should return to normal operation and FAC icon is visible.

CONFIGURATION

Configuration determines what information is present on the LCD display. For instance, total, flowrate, type of calibration, etc.

The Display has been programmed with many features, which can be enabled by the end user through the configuration process. By disabling unnecessary features, day-to-day flowmeter operation can be greatly simplified, making the unit easier to use. Alternately, there are several features not found in the default configuration.

Available features include:

- 0 to 3 totals, either resettable (Batch) or non-resettable (Cumulative).
- Flowrate or no flowrate. Available in units per minute, hour or day.
- Three different field calibration methods: K-factor entry, Dispense/Display or % Correction Factor.
- Various units of measure (some or all): GL (gallon), LT (litre), IGL (imperial gallon), QT (quart), CF (cubic feet), CM (cubic meter), BL (42 gal. barrel), CC (cubic centimeter) or OZ (ounce).

Changing Configuration Settings

Access to the configuration settings require a specific procedure and a pin code available through the GPI Website at www.gpimeters.net or call GPI Customer Service at 888-996-3837.

MAINTENANCE

Replacing the Battery

Replace the battery when the readout becomes dim or blank. Replace the battery with a 9-volt lithium battery. Order GPI part number 902006-44.

To replace the battery:

1. Remove the two large screws and two small screws from the battery coverplate.
2. Remove the battery coverplate and gasket.

3. Remove the battery and clean any corrosion from the terminals.

NOTE: Coat the terminals with petroleum jelly to protect against corrosion.

4. Install the new battery.
5. Check the gasket for damage and replace as needed. Position gasket and coverplate to align, insert screws and tighten.

NOTE: Batch and Cumulative Totals, as well as the factory calibration are retained in the computer permanently and will display when the battery is replaced.

TROUBLESHOOTING

SYMPTOM	PROBABLE CAUSE	CORRECTIVE ACTION
A. LCD REGISTER NOT WORKING	<ol style="list-style-type: none">1. Battery not connected properly2. Battery flat3. Faulty wiring connections4. Faulty LCD5. Faulty connection from computer to Pulse PCB	<p>Check battery connections.</p> <p>Replace battery.</p> <p>Check wiring for loose or faulty connections.</p> <p>Replace computer assembly.</p> <p>Check wiring connections.</p>

ILLUSTRATED PARTS DRAWING – GG510 & GM SERIES GM005-GM020

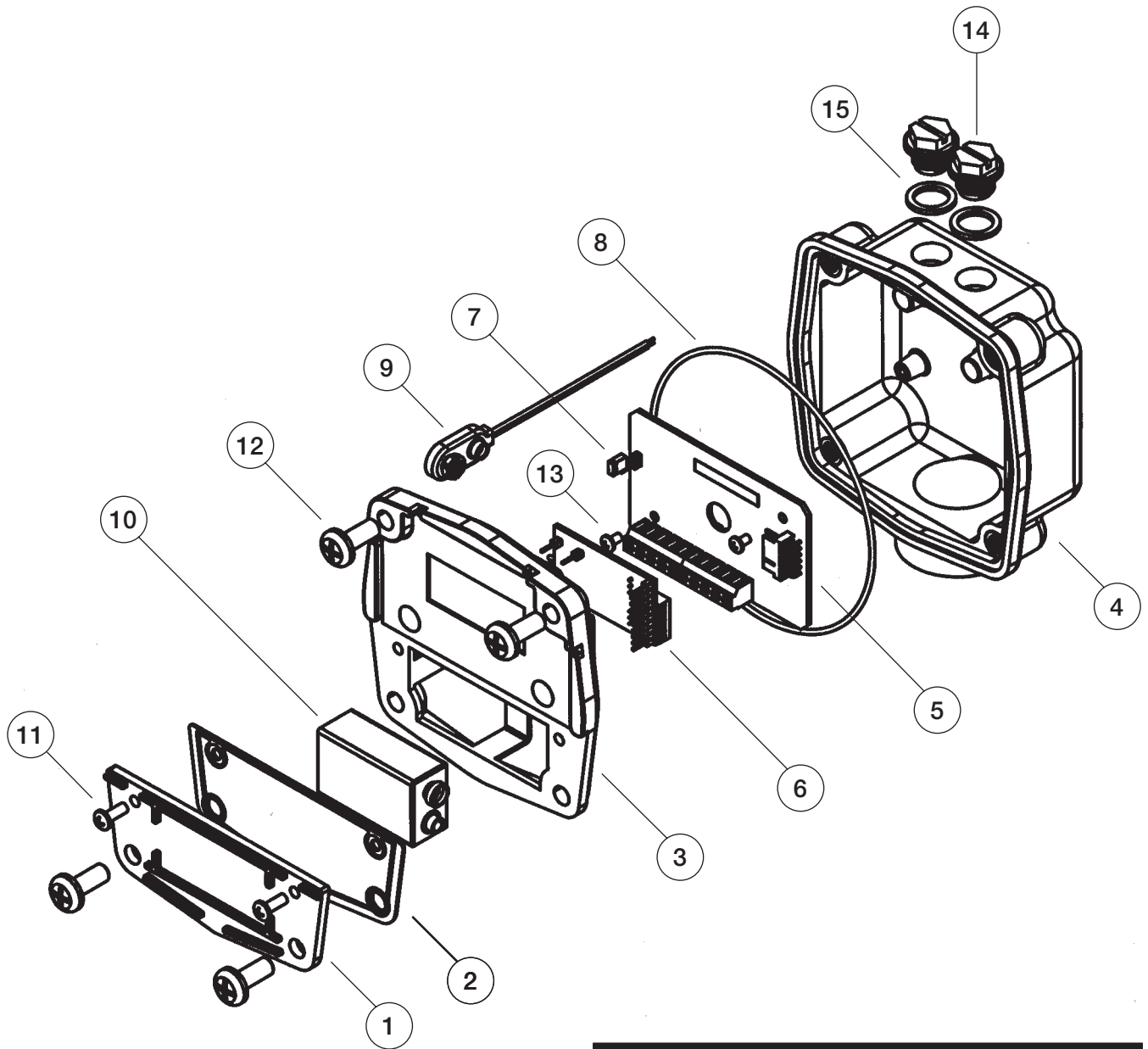

Item No.	Part No.	Description	No. Req'd.
1	120009-2	Battery Cover	1
2	120028-1	Battery Gasket.....	1
3	12051801	Computer Kit (Hours).....	1
	12051802	Computer Kit (Minutes)	1
4	12051701	Adapter Kit (GG510)	1
	120509-02	Adapter Kit (GM005 & GM007) - Local	1
	120509-03	Adapter Kit (GM010, GM015 & GM020) - Local.....	1
5	12009601	Circuit Assembly (Core).....	1
6	12009801	Circuit Assembly (Pigtail).....	1
7	42100117	Jumper (2-Circuit).....	1
8	901002-82	O-Ring	1
9	902004-97	Battery Terminal.....	1
10	902006-44	Battery, 9-volt Lithium	1
11	904005-27	Sems Screw, 6-32 x 3/8 in. & Plain Washer	2
12	904005-28	Sealing Screw, 1/4-20 x 5/8 in., m SS, Viton.....	4
13	904005-63	Screw, 4-40 x 3/16 in., X-Recess.....	2
14	906005-47	Threaded Plug	2
15	906005-48	Seal.....	2

ILLUSTRATED PARTS DRAWING – GG500, G2 SERIES & GM SERIES GM001-GM003

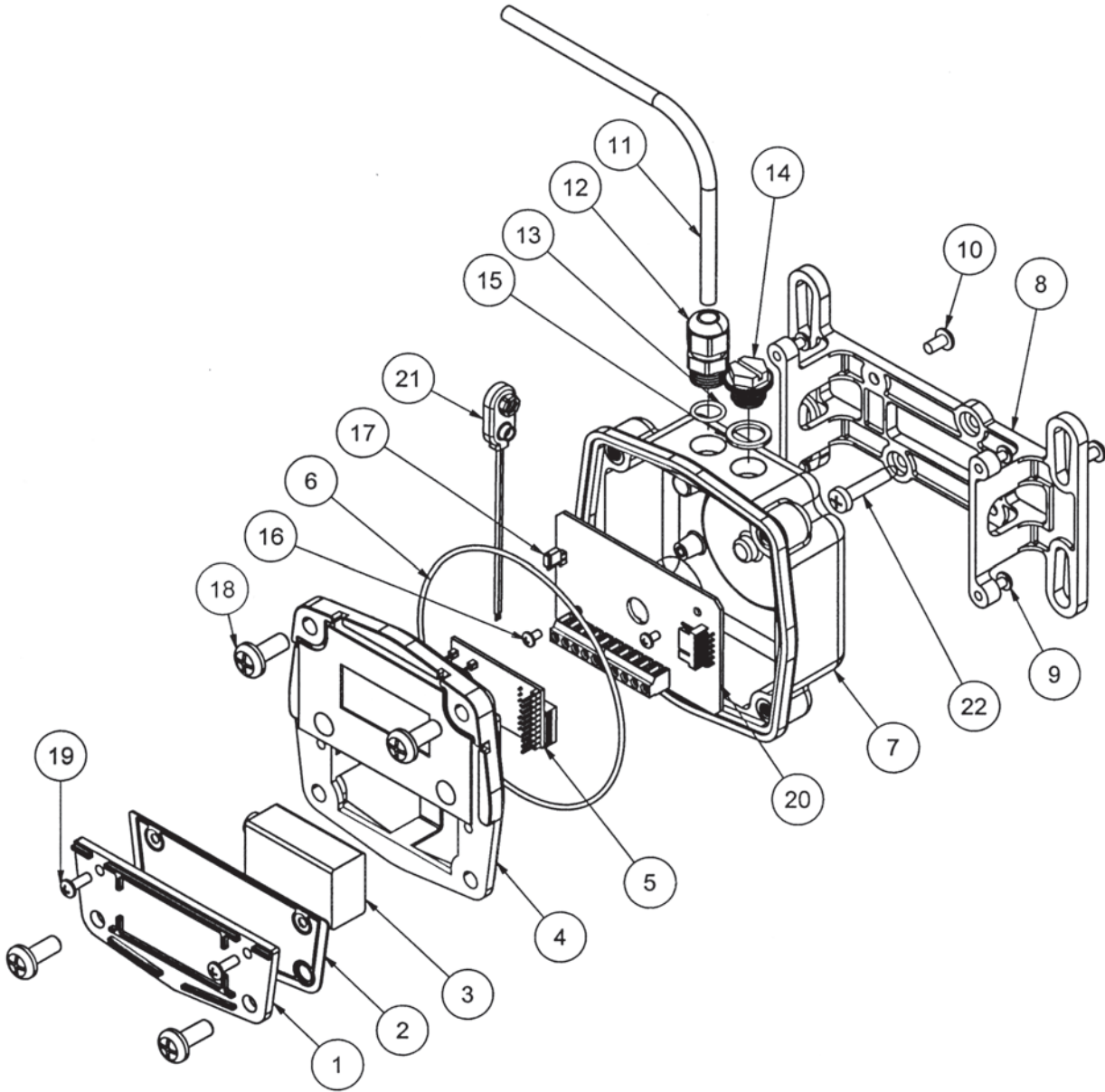

Item No.	Part No.	Description	No. Req'd.
1	120009-2	Battery Cover	1
2	120028-1	Battery Gasket.....	1
3	902006-44	Battery, 9-volt Lithium	1
4	12051801	Computer Kit (Hours).....	1
	12051802	Computer Kit (Minutes)	1
5	12009801	Circuit Assembly (Pigtail).....	1
6	901002-82	O-Ring.....	1
7	120509-01	Adapter Kit - Remote Display & Local (GM001, GM002 & GM003).....	1
8	120058-01	Bracket	1
9	904005-13	Screw, 6-32 x 1/2 in. (Remote Model).....	4
10	904002-44	Screw, 8-32 x 5/16 in.	2
11	125066-20	Cable, 20 ft.	1
	125066-3	Cable, 100 ft.	1

Item No.	Part No.	Description	No. Req'd.
12	902005-9	Strain Relief	1
13	901002-87	O-Ring	1
14	906005-47	Threaded Plug	1
15	906005-48	Seal.....	1
16	904005-63	Screw, 4-40 x 3/16 in.	2
17	42100117	Jumper (2-Circuit).....	1
18	904005-28	Sealing Screw, 1/4-20 x 5/8 in.	4
19	904005-27	Sems Screw, 6-32 x 3/8 in.	2
20	12009601	Circuit Assembly (Core).....	1
21	902004-97	Battery Terminal.....	1
22	904006-94	Screw, 10-16 x 5/8 in. (GM001, GM002 & GM003).....	2
	12051901	Battery Conversion Kit (not shown) - Kit includes Items 3, 14, 15 and 21.....	1

SPECIFICATIONS – LOCAL MODEL

Materials:

Acetal, Amorphous Nylon, PET Polyester, Polyester (de-cals), Viton (gasket & seals), Stainless Steel (fasteners)

Power Source:

Battery (9V): 6.5V to 20V acceptable range.

Quiescent current (over and above current drawn by display module) at the battery input is typically less than 15uA.

External Power: 7V to 30V acceptable range. Quiescent current (over and above current drawn by display module) at the external power input is typically less than 90uA.

Battery Life:

5 years

Configuration:

2-Totals (1 cumulative and 1 batch), Rate, 2 Cals
(Factory calibration in gallons or litres; 1 field calibration)

Input Signal:

Hall Effect, Reed Switch, NPN, Open Collector or Sine Wave

Time Base:

Hours or minutes

Unit of Measure:

U.S. gallons or litres

Accuracy:

No additional error over coupled flow meter's accuracy

Frequency Range:

0 to 1,000 hertz

Batch Total:

Up to 999,999 (x100)

Cumulative Total:

Up to 999,999 (x100)

Temperature:

0° F to +140° F (-18° C to +60° C)

Cable:

N/A

Mechanical Connections:

Display is mounted directly to flow meter body

Electrical Connections:

GG500 - One strain relief port: one threaded plug

GG510 - Two threaded plugs

G2 Series - One strain relief port: one threaded plug

GM Local Models - One strain relief port: one threaded plug (GM001, GM002 & GM003)

GM 1/2 in. and Larger - Two threaded plugs (GM005 - GM020)

Shipping Weight:

1 lb. (.45 kg)

SPECIFICATIONS – REMOTE MODEL

Materials:

Acetal, Amorphous Nylon, PET Polyester, Polyester (de-cals), Viton (gasket & seals), Stainless Steel (fasteners), PVC (cable jacket)

Power Source:

Battery (9V): 6.5V to 20V acceptable range.

Quiescent current (over and above current drawn by display module) at the battery input is typically less than 15uA.

External Power: 7V to 30V acceptable range. Quiescent current (over and above current drawn by display module) at the external power input is typically less than 90uA.

Battery Life:

5 years

Configuration:

2-Totals (1 cumulative and 1 batch), Rate, 2 Cals
(Factory calibration in gallons or litres; 1 field calibration)

Input Signal:

Hall Effect, Reed Switch, NPN, Open Collector or Sine Wave

Time Base:

Hours or minutes

Unit of Measure:

U.S. gallons or litres

Accuracy:

No additional error over coupled flow meter's accuracy

Frequency Range:

0 to 1,000 hertz

Batch Total:

Up to 999,999 (x100)

Cumulative Total:

Up to 999,999 (x100)

Temperature:

0° F to +140° F (-18° C to +60° C)

Cable:

20 feet, 3-conductor (red, black & white), tinned drain wire, 22 AWG, PVC jacket .212 dia., (Reference Belden 9363 or equivalent cable)

Mechanical Connections:

Wall or pipe mountable with standard U-bolts

Electrical Connections:

GG500 - One strain relief port: one threaded plug

GG510 - Two threaded plugs

G2 Series - One strain relief port: one threaded plug

GM Local Models - One strain relief port: one threaded plug (GM001, GM002 & GM003)

GM 1/2 in. and Larger - Two threaded plugs (GM005 - GM020)

Shipping Weight:

1 lb. (.45 kg)

DIMENSIONAL DRAWINGS

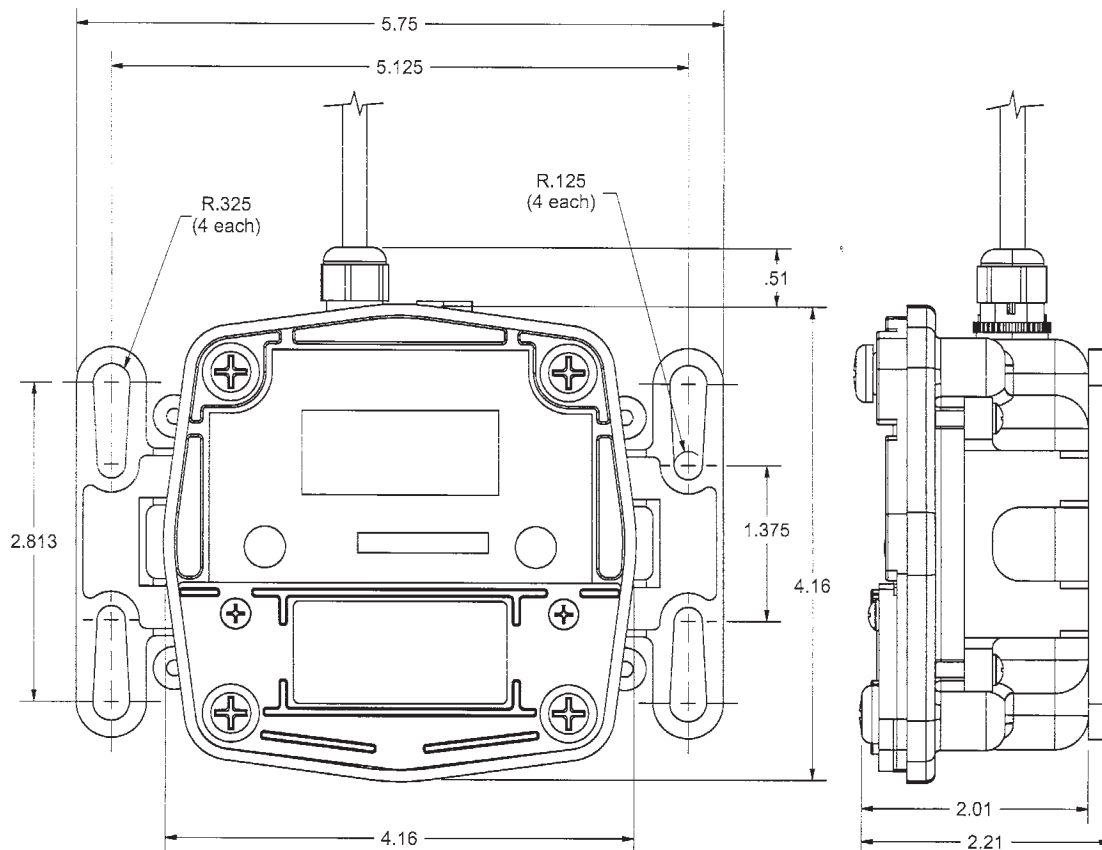
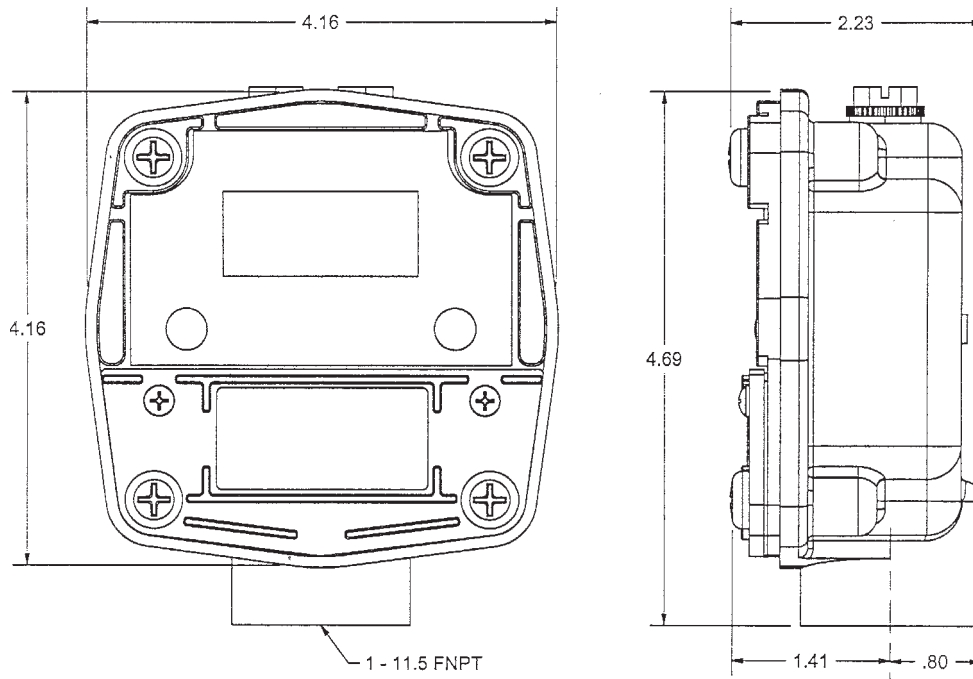

SERVICE

For warranty consideration, parts, or other service information, please contact your local distributor. If you need further assistance, contact the GPI Customer Service Department in Wichita, Kansas, Monday-Friday, 8:00 a.m. to 5:00 p.m. Central time.

Tel: 316-686-7361

Fax: 316-686-6746

Toll free: 1-888-996-3837

To obtain prompt, efficient service, always be prepared with the manufacturing date code, found behind the coverplate.

For warranty work, always be prepared with your original sales slip or other evidence of purchase date.

Please contact GPI before returning any part. It may be possible to diagnose the trouble and find a solution with a telephone call. GPI can also inform you of any special requirements you will need to follow for shipping.

WEEE DIRECTIVE



The Waste Electrical and Electronic Equipment (WEEE) directive (2002/96/EC) was approved by the European Parliament and the Council of the European Union in 2003. This symbol indicates that this product contains electrical and electronic equipment that may include batteries, printed circuit boards, liquid crystal displays or other components that may be subject to local disposal regulations at your location. Please understand those regulations and dispose of this product in a responsible manner.

Limited Warranty Policy

Great Plains Industries, Inc. 5252 E. 36th Street North, Wichita, KS USA 67220-3205, hereby provides a limited warranty against defects in material and workmanship on all products manufactured by Great Plains Industries, Inc. This product includes a 1 year warranty. Manufacturer's sole obligation under the foregoing warranties will be limited to either, at Manufacturer's option, replacing or repairing defective Goods (subject to limitations hereinafter provided) or refunding the purchase price for such Goods theretofore paid by the Buyer, and Buyer's exclusive remedy for breach of any such warranties will be enforcement of such obligations of Manufacturer. The warranty shall extend to the purchaser of this product and to any person to whom such product is transferred during the warranty period.

The warranty period shall begin on the date of manufacture or on the date of purchase with an original sales receipt. This warranty shall not apply if:

- A. the product has been altered or modified outside the warrantor's duly appointed representative;
- B. the product has been subjected to neglect, misuse, abuse or damage or has been installed or operated other than in accordance with the manufacturer's operating instructions.

To make a claim against this warranty, contact the GPI Customer Service Department at 316-686-7361 or 888-996-3837. Or by mail at:
Great Plains Industries, Inc.
5252 E. 36th St. North
Wichita, KS, USA 67220-3205

The company shall, notify the customer to either send the product, transportation prepaid, to the company at its office in Wichita, Kansas, or to a duly authorized service center. The company shall perform all obligations imposed on it by the terms of this warranty within 60 days of receipt of the defective product.

GREAT PLAINS INDUSTRIES, INC., EXCLUDES LIABILITY UNDER THIS WARRANTY FOR DIRECT, INDIRECT, INCIDENTAL AND CONSEQUENTIAL DAMAGES INCURRED IN THE USE OR LOSS OF USE OF THE PRODUCT WARRANTED HEREUNDER.

The company herewith expressly disclaims any warranty of merchantability or fitness for any particular purpose other than for which it was designed.

This warranty gives you specific rights and you may also have other rights which vary from U.S. state to U.S. state.

Note: In compliance with MAGNUSON MOSS CONSUMER WARRANTY ACT – Part 702 (governs the resale availability of the warranty terms).



5252 East 36th Street North
Wichita, KS USA 67220-3205
TEL: 316-686-7361
FAX: 316-686-6746

GREAT PLAINS INDUSTRIES, INC.

"A Great Plains Ventures Subsidiary"

www.gpimeters.net

1-888-996-3837