

EQUFLOW**SS(0045, 0085, 00125) Stainless Steel Turbine Flow Sensor**

SS wetted parts, F.S. ranges of 2, 20, & 40 lpm, Frequency Output

DESCRIPTION

Model SS flow sensor has low flow sensing capabilities in a wide range of applications, and is suitable for clear, opaque, neutral, corrosive and aggressive liquids. It has a rugged stainless steel housing and is available with threaded or Tri-Clamp end connections.

An ultra light-weight turbine follows the fluctuation of flow very accurately and generates a high resolution IR reflected digital output signal.

K-factors (pulses per liter) are factory determined and provided for each flow tube. Customer specified K-factors can be accommodated and are programmed at the factory.

External optional electronic packages include model PD6300 Flow rate indicator and totalizer and PD6310 batch controllers. Rich in features, these products provide complete solutions for monitoring and batching applications.

**Features**

- Turbine flowsensor with high resolution output
- Flow measuring by revolutionary IR turbine reflection
- 316 Stainless Steel & PFA parts for high chemical and corrosion resistance
- High accuracy and repeatability
- Suitable for opaque liquids
- Programmable K-factor (at factory)

SPECIFICATIONS

Patent No. US5388466

GENERAL

Model	SS0045	SS0085	SS0125
Inner diameter in mm	4.5	8.5	12.5
Flow range	0.1 - 2 L/min ¹	0.5 - 20 L/min	1.5 - 40 L/min
Accuracy	1% of reading	1% of reading	1% of reading
Repeatability	< 0.15 %	< 0.15 %	< 0.15 %
Wetted parts	316 SS/PFA /Ruby	316 SS/PFA /Ruby	316 SS/PFA /Ruby
O-ring Seals	Viton or EPDM	Viton or EPDM	Viton or EPDM
Tube connection thread	1/4 " NPT/BSP	3/8 "NPT/BSP	1/2 " NPT/BSP
Tri-Clamp Connection Option	3/4"	3/4"	1"
Liquid temperature in °C	-20 to +80	-20 to +80	-20 to +80
Max. pressure at 20° C in bar (psi)	100 (1,450)	100 (1,450)	100 (1,450)
Viscosity in cSt.	0.8 - 10	0.8 - 10	0.8 - 10
K factor ² (water) in pulse/Litre (nominal)	110,000	5,500	2,000
Power supply	5 - 30 Vdc	5 - 30 Vdc	5 - 30 Vdc
Output signal	5 - 30 V sq. wave	5 - 30 V sq. wave	5 - 30 V sq. wave
Power consumption	35 mA at 5 V	35 mA at 5 V	35 mA at 5 V
Electrical lead	PVC 1 meter	PVC 1 meter	PVC 1 meter
Dimensions incl. housing (mm)	L-72.6, ø 40	L-72.3, ø 40	L-73.6, ø 40
Recommended Line filter	100 µm	100 µm	150 µm

¹Special Low Flow Sensor 0045 available with flow range: 0.02-1.0 L/min

²K-factors (pulses per liter) are factory determined and provided for each flow tube. Customer specified K-factors can be accommodated and are programmed at the factory.

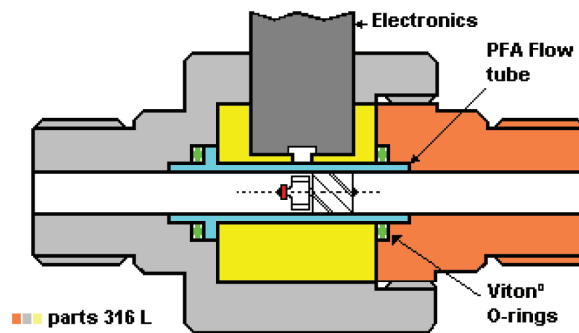

Working Principal:

A static worm forces the passing fluid to spin. The spinning fluid drives a rotor with reflectors into a frictionless rotation. A high resolution infrared sensor determines the rate of flow by counting the passing reflections. The set up even allows the flow of opaque liquids to be determined accurately. The ultra low mass of the rotor guarantees a quick response to changes in the rate of flow

Wiring:

Power Supply 5-30 Vdc or 5 Vdc (low voltage option)

Output All Sensors: NPN square wave

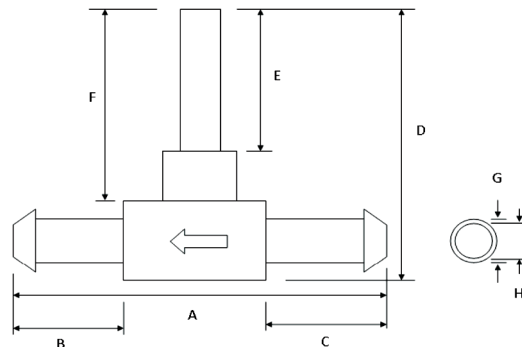
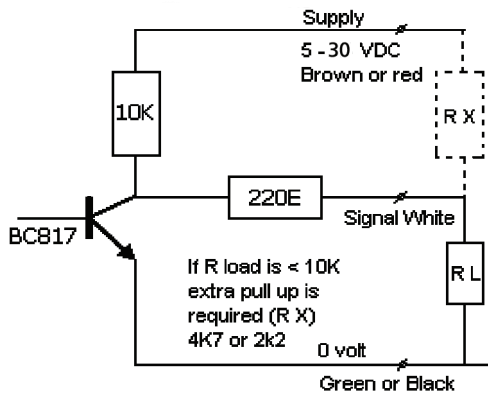

Dim. (MM)	0045- NPT	0045-BSP	0085- NPT	0085- BSP	0125- NPT	0125- BSP
A	72.5	67	72.3	67.2	73.8	71.2
B	14.7	14.4	14.8	12.35	15.5	14.2
C	14.7	14.4	14.8	12.35	15.5	14.2
D	68.5	68.5	71.2	71.2	76	76
E	28.5	28.5	30.3	30.3	30	30
F	12	12	12	12	12	12
G	13.8	13.8	17.2	17.2	21.7	21.7
H	4.5	4.5	8.85	8.85	14	14
I	40	40	40	40	45	45

ORDERING INFORMATION

**ABCDEFGH
SS0045SNP01XA**

A Model	B Tube Dia./Range	C Wetted Material	D Connection	E Cable Type	F Cable Length	G Version	H Power
SS	0045= 4.5 mm/0.1-2 l/min 0085= 8.5 mm/1.0-20 l/min 0125= 12.5 mm/2.0-38 l/min	S=316 SS/PFA /Ruby	N= NPT B= BSP T= Tri-Clamp	P= PVC	01= 1 meter (Standard) 02= 2 meters	X= Fixed housing	A= 5-30 VDC

Ask About Our Other Equiflow Products.....

- Standard Flow Sensor
- Disposable Flow Sensor
- Electronic packages for use with Flow Meters
- PD6300 Flow rate indicator and totalizer
- PD6310 batch controllers

